

AUTO Mute Test By Using Data Sets from September 1, 2020

Choon Park, Ph.D.

**Principal Geophysicist
Park Seismic LLC**



Seismic Approach to Quality Management of HMA

MnDOT Contract No. 1034287

Federal Project Number: TPF-5 (341)

Execution: January, 2020 - December, 2021

Principal Investigator: *Choon Park*, Park Seismic LLC, Shelton, Connecticut, USA

Co-Investigators: *Nils Ryden* and *Josefin Starkhammar*, Norfee Tech, Lund, Sweden

Administrative Staff: *Jin Park*, Park Seismic LLC, Shelton, Connecticut, USA

SUMMARY

- New field operations were conducted on September 1, 2020, at the same place used previously for data sets collected during July and August. Among many 48-channel records collected (about 500 of them), two TDMS files were obtained from the Team Sweden; i.e., “2020-09-01_19_12.TDMS” and “2020-09-01_19_24.TDMS” files that contained 100 and 50 field records, respectively. The same pre-trigger time of 0.5-ms was used. This 0.5-ms time, firstly used in August, turned out later (late August) too short to capture the earlier-arrival Lamb waves for the records obtained from the reverse shots (i.e., from the impact by the source attached on the back-side of the receiver array off the 48th channel) because of the longer distance between the impact point and the array.
- There was a total of 32 reverse-shot records for the “2020-09-01_19_12.TDMS” data set that contained a total 100 records, while all 50 records were from the forward shots for the “2020-09-01_19_24.TDMS” data set.
- First, the AUTO Mute algorithm previously developed and tested on a limited amount of field records (e.g., data sets from July and August) has been tested on these two data sets to evaluate the accuracy in the muting windows for air-wave and pre-Lamb waves. Results for all 150 records showed the AUTO Mute was highly effective when the raw records and the muted records were visually compared side-by-side. These comparisons of seismic records are presented in this report.
- Second, data qualities are examined in dispersion images to evaluate the effective recording of Lamb waves. While all reverse-shot records did not have any Lamb waves in the target frequency bands that are needed for the velocity (V_s) and thickness (H) evaluations (e.g., 10 kHz – 30 kHz), 54 forward-shot records (out of 68 such records) were in good quality that can allow a reliable V_s and H evaluations for the “2020-09-01_19_12.TDMS” data set. On the other hand, 39 records (out of 50) were in good quality for the “2020-09-01_19_24.TDMS” data set. These results put the “accept” rate of 80% and 78% for the two respective data sets.

SUMMARY (cont'd)

- Study of the optimum configuration for the 1D array has been one of the main goals of using the old (48-channel) system to collect field data under various different conditions (e.g., different section of the road, different temperatures, different source characteristics, etc.). Based on the test results from a limited amount of field data sets (e.g., the ones from July and August), it has been tentatively assumed that the 16-channel array with 3 times receiver spacing (i.e., 3dx) would be the most optimum configuration.
- With relatively vast amount of field records now available (i.e., 150), the test has been repeated to reinsure this 3-dx-16-channel assumption. This time, the AUTO Mute was applied to both full 48-channel records and the resampled 3dx-16-channel records to examine if there is any reduction in the effectiveness due to the reduced number of channels. The AUTO Mute results of 48-channel and 3dx-16-channel records are presented side-by-side in this report for visual comparison.
- Then, dispersion images for the 3dx-16-channel records were obtained and compared side-by-side with those from the full (48) channel records by displaying them for the “2020-09-01_19_12.TDMS” data set in this report.
- No noticeable visual differences were observed from both the raw-seismic-data and the dispersion-image comparisons for the target frequency band (e.g., 10 kHz – 30 kHz). However, more systematic comparisons will be made in the near future by comparing key analysis results (e.g., Vs and H) from both data sets.

Data (September 1, 2020)

- **“2020-09-01_19-12.TDMS”**
 - Total 100 records of 48-channel records from both forward (68) and reverse (32) shots
 - 0.5-ms Pre-trigger time
 -  = Reverse shot record

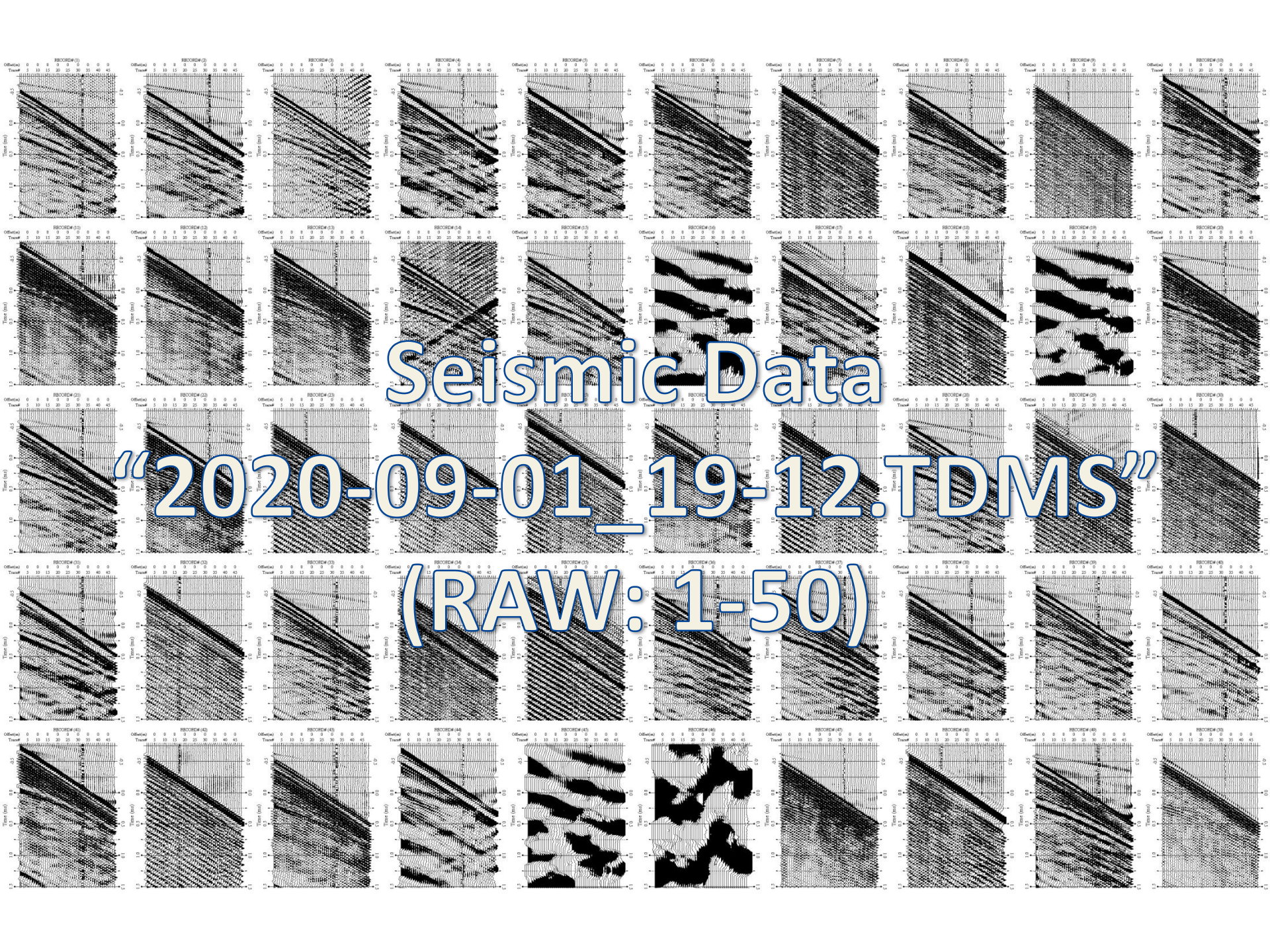

Seismic Data

“2020-09-01_19-12.TDMS”

(RAW: 1-50)



Seismic Data

“2020-09-01_19-12.TDMS”

(AUTO Mute: 1-50)

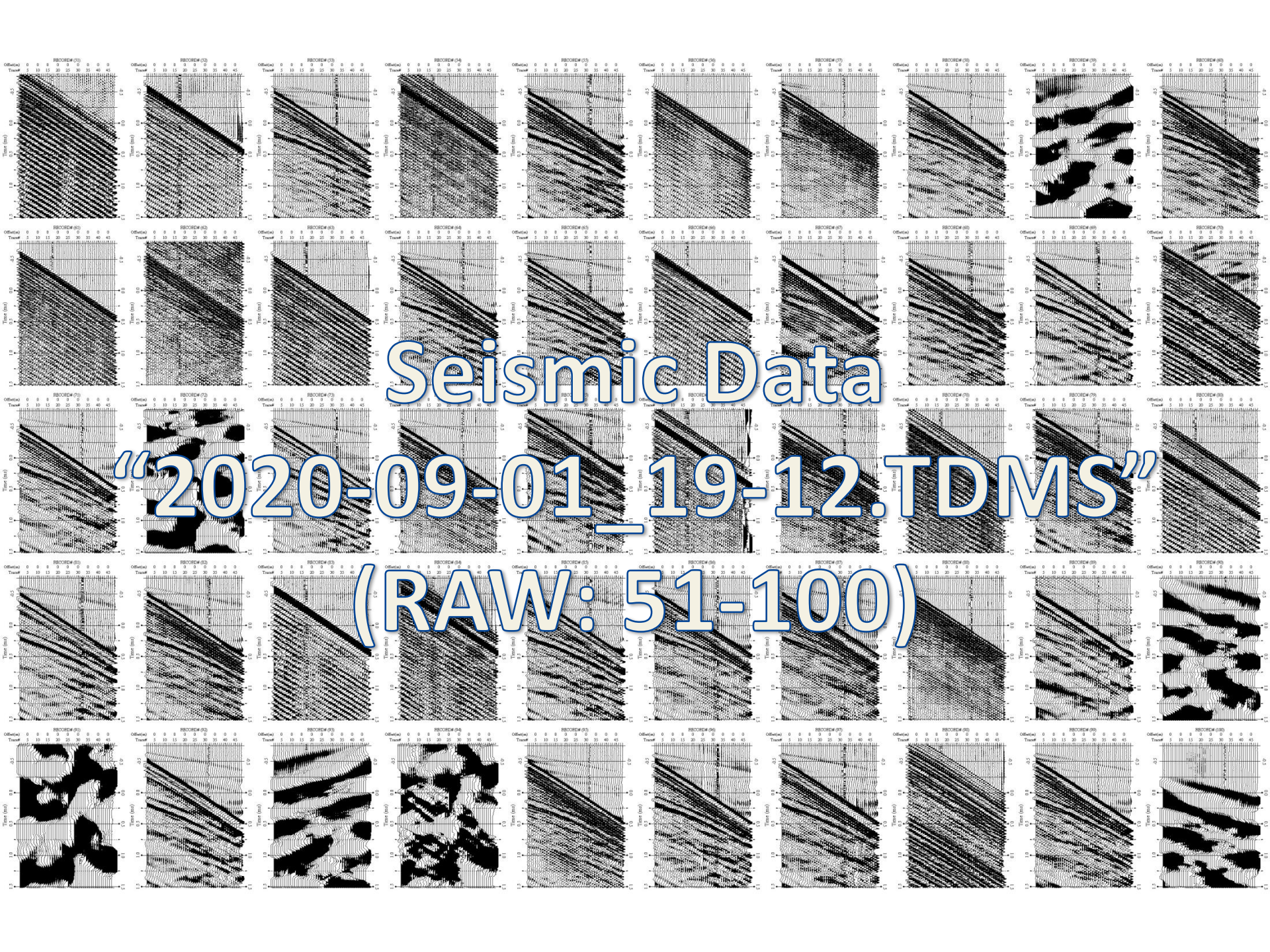

Seismic Data

“2020-09-01_19-12.TDMS”

(RAW: 51-100)

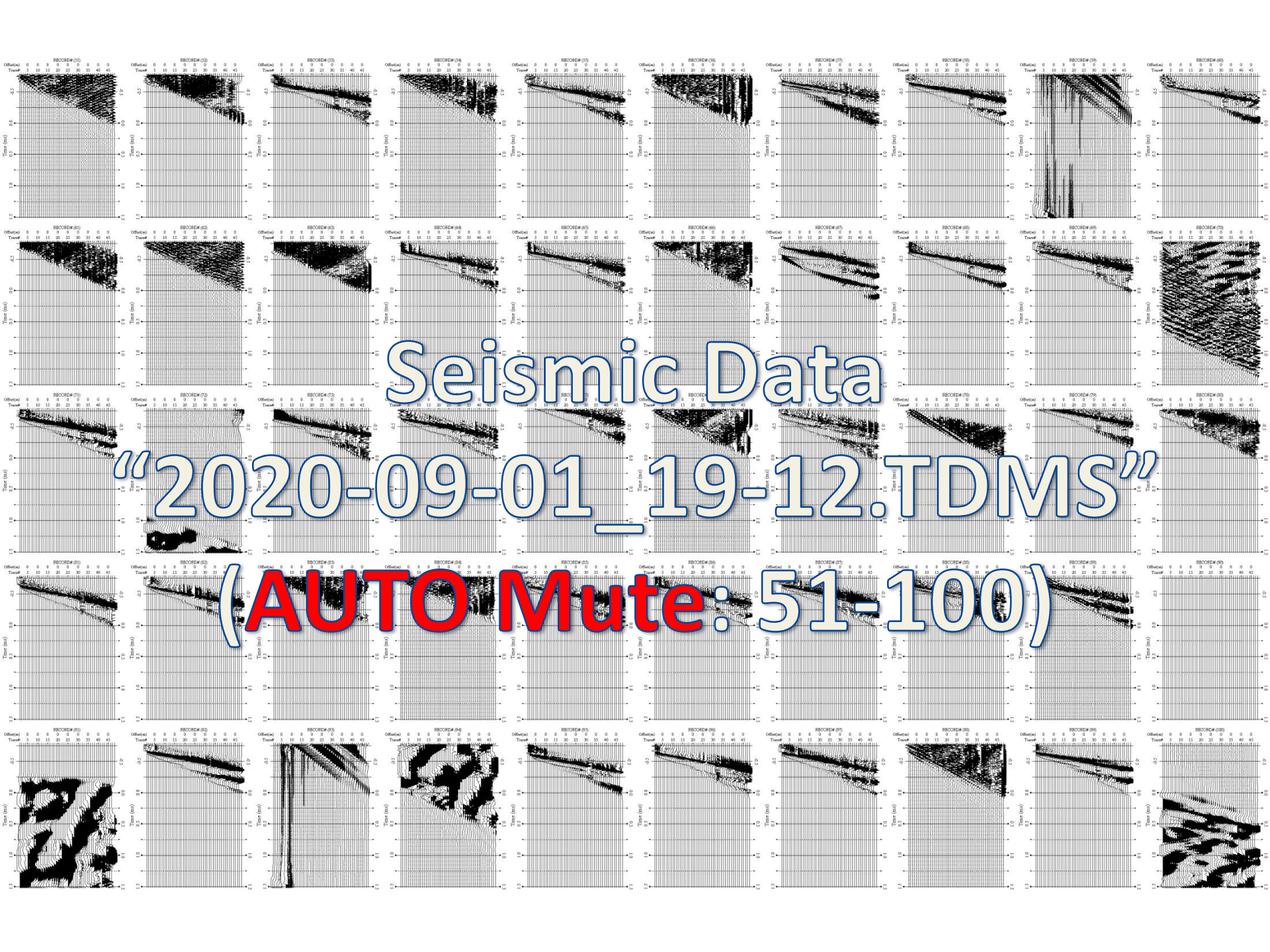

Seismic Data

“2020-09-01_19-12.TDMS”

(AUTO Mute: 51-100)

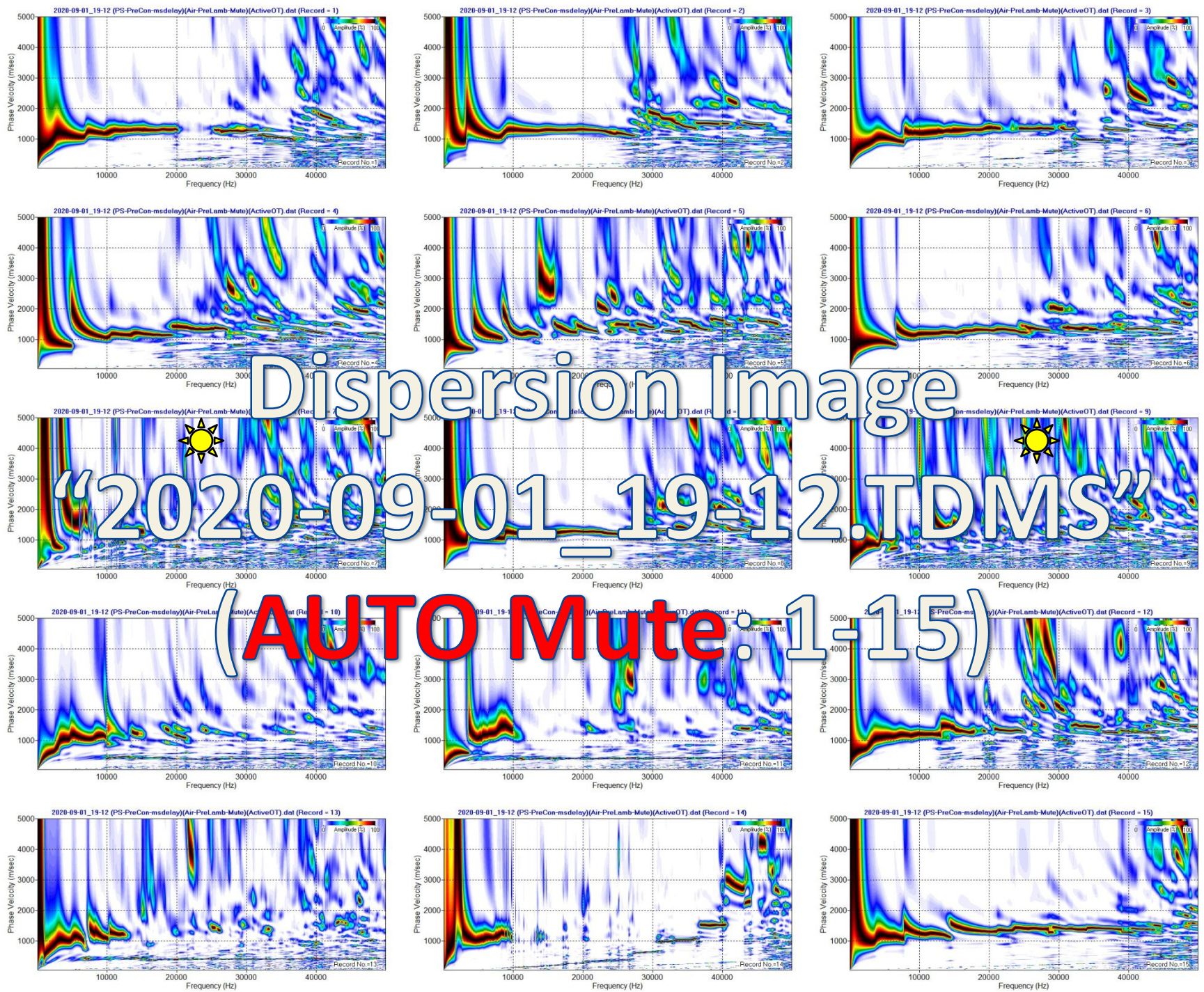

Dispersion Image

“2020-09-01_19-12.TDMS”

(AUTO Mute: 1-15)

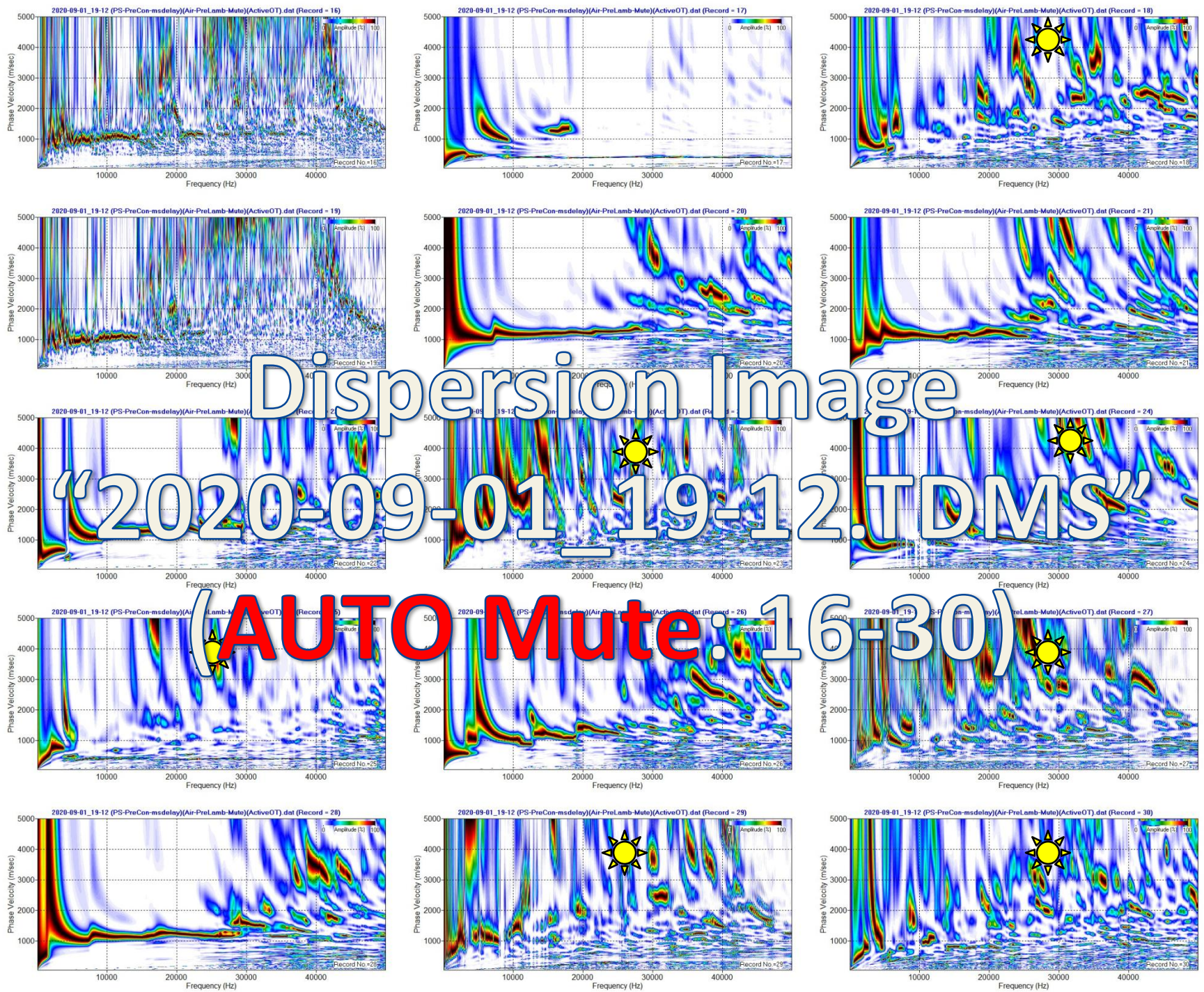

Dispersion Image

“2020-09-01_19-12.TDMS”

(AUTO Mute: 16-30)

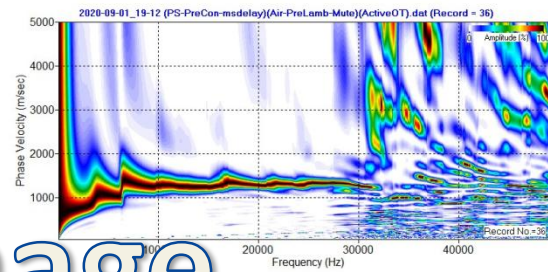
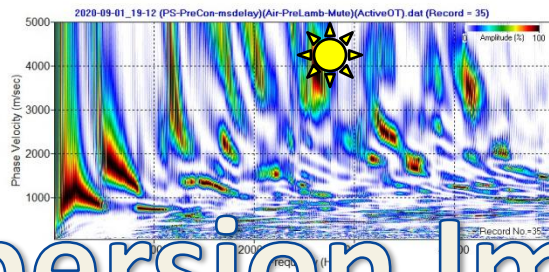
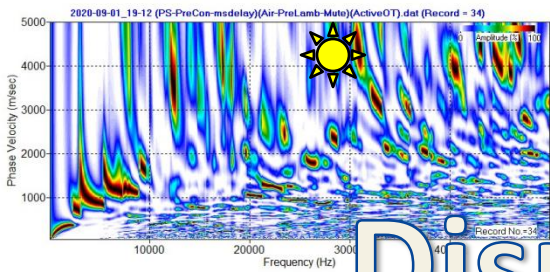
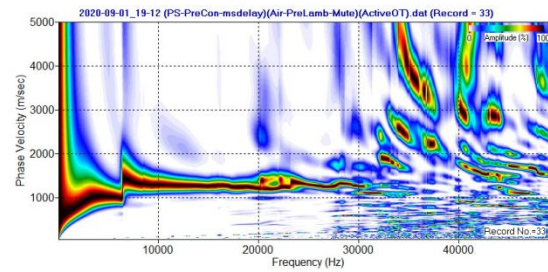
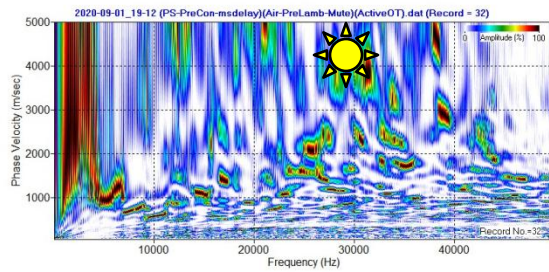
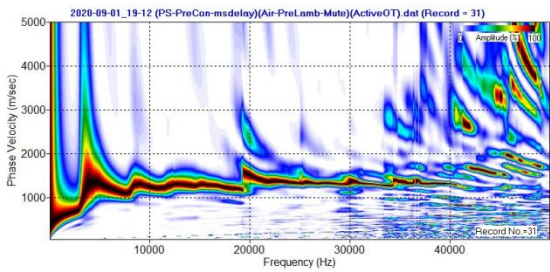

Dispersion Image

"2020-09-01_19-12.TDMS"

(AUTO Mute: 31-45)

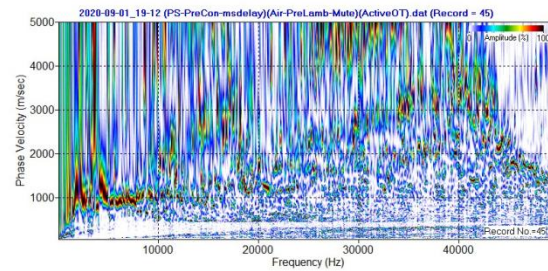
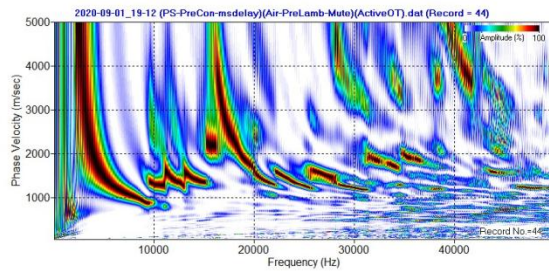
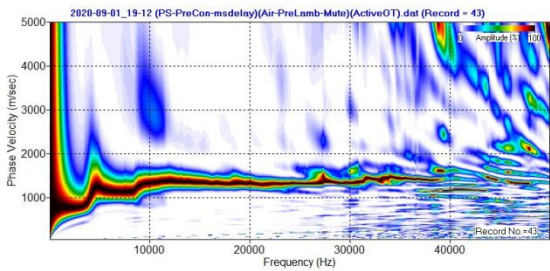
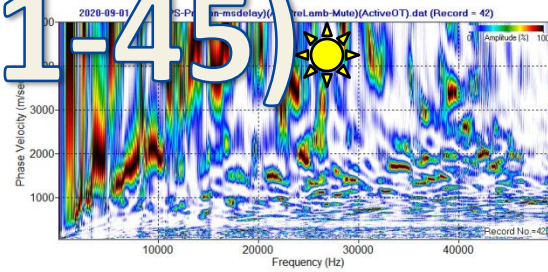
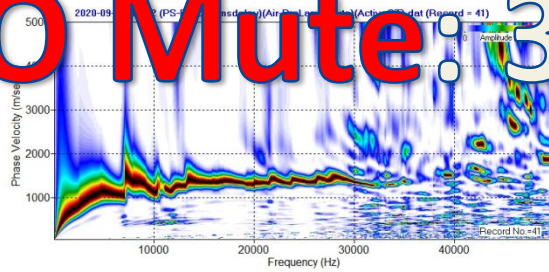
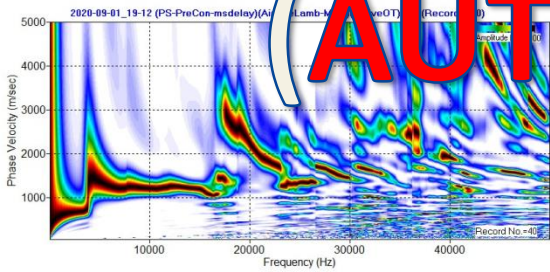
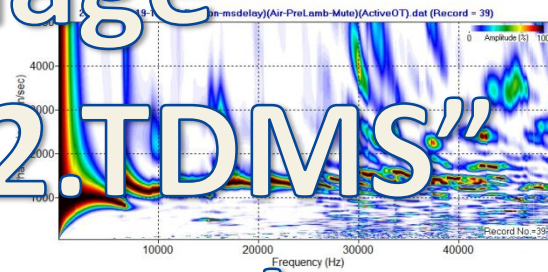
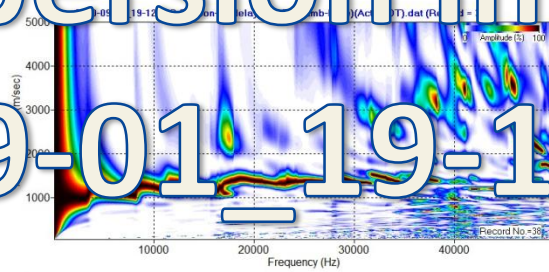
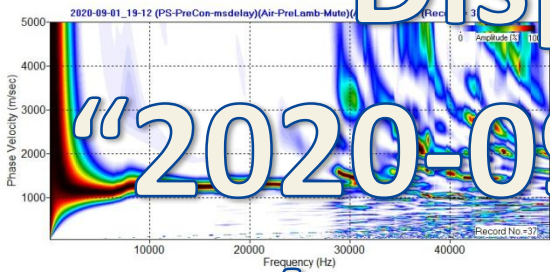

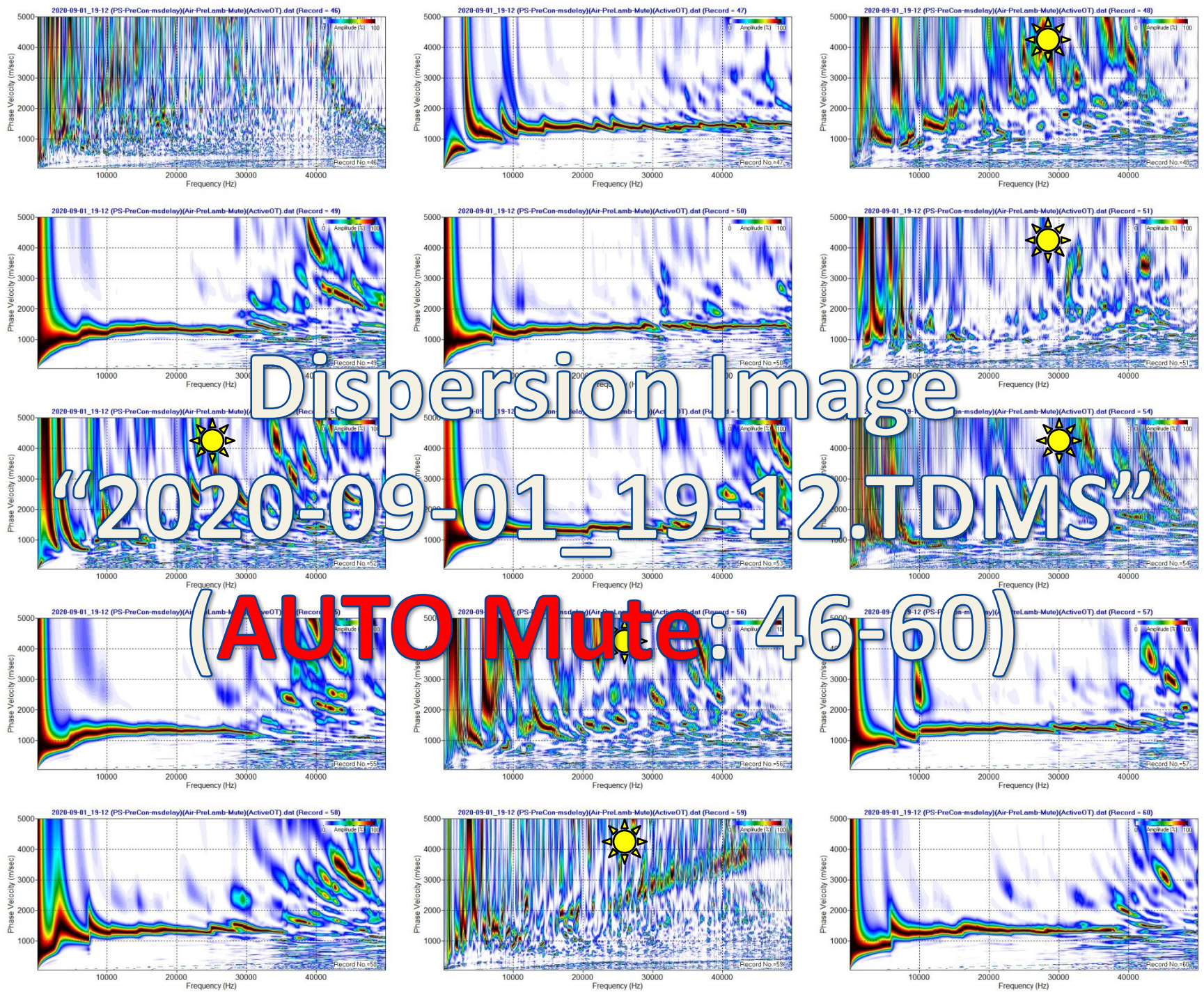

Dispersion Image

“2020-09-01_19-12.TDMS”

(AUTO Mute: 46-60)

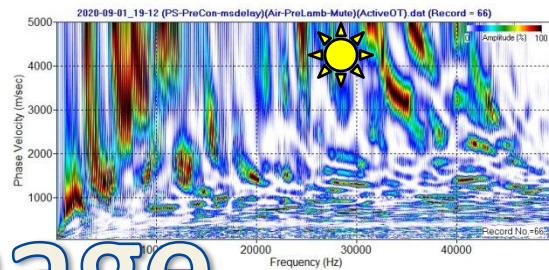
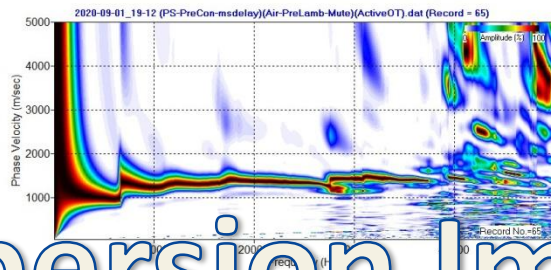
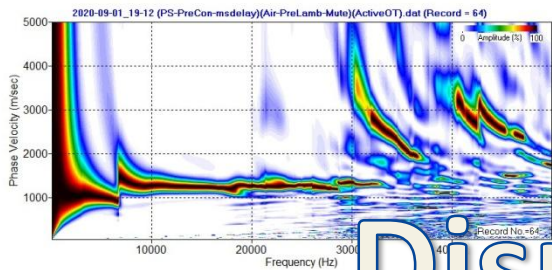
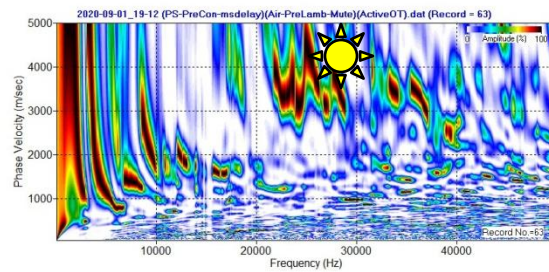
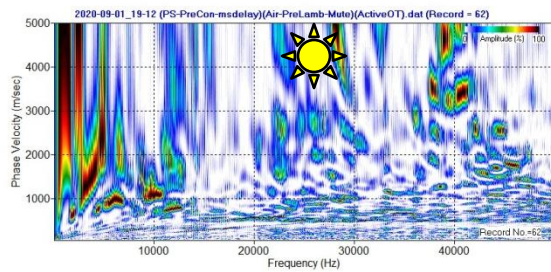
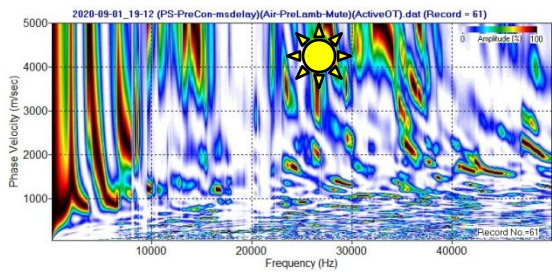

Dispersion Image

“2020-09-01_19-12.TDMS”

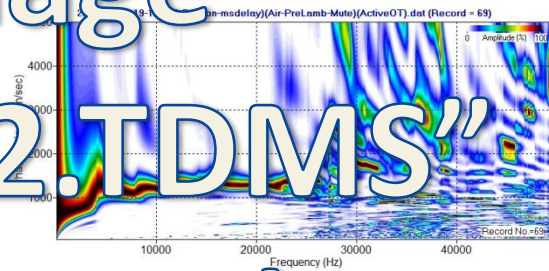
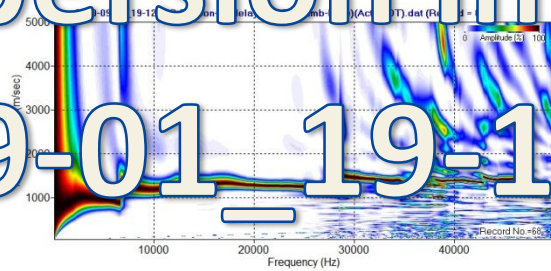
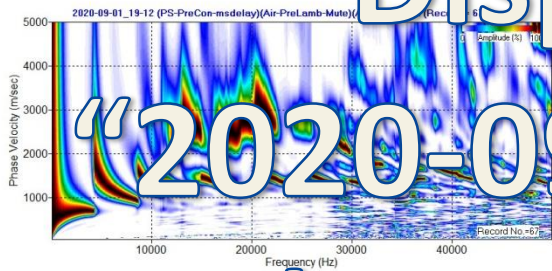

(AUTO Mute: 61-75)

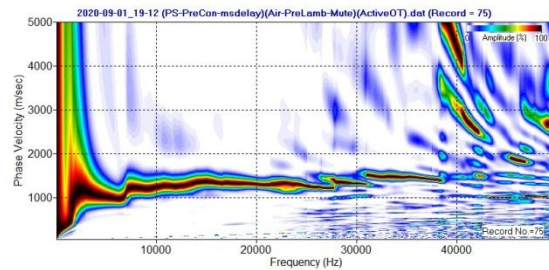
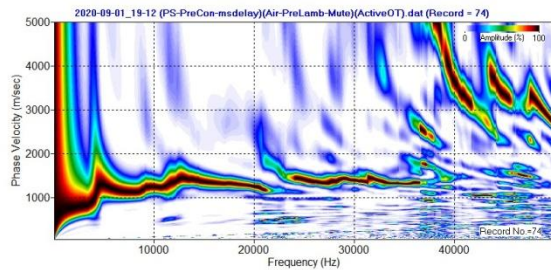
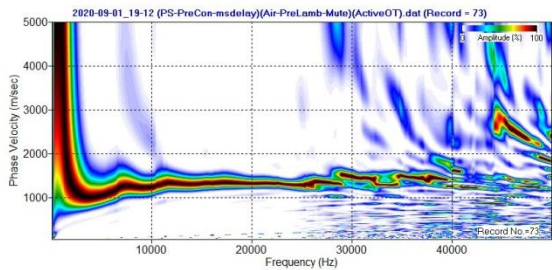
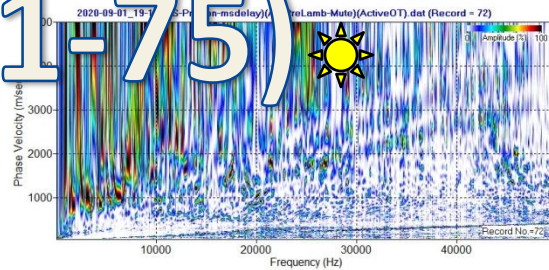
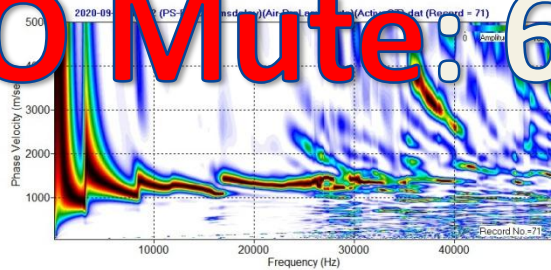
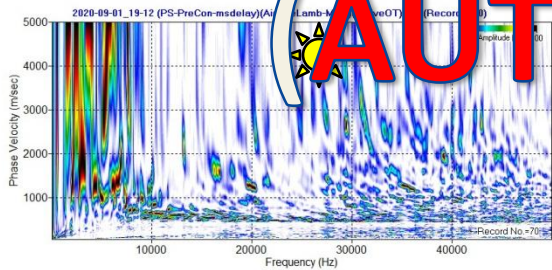

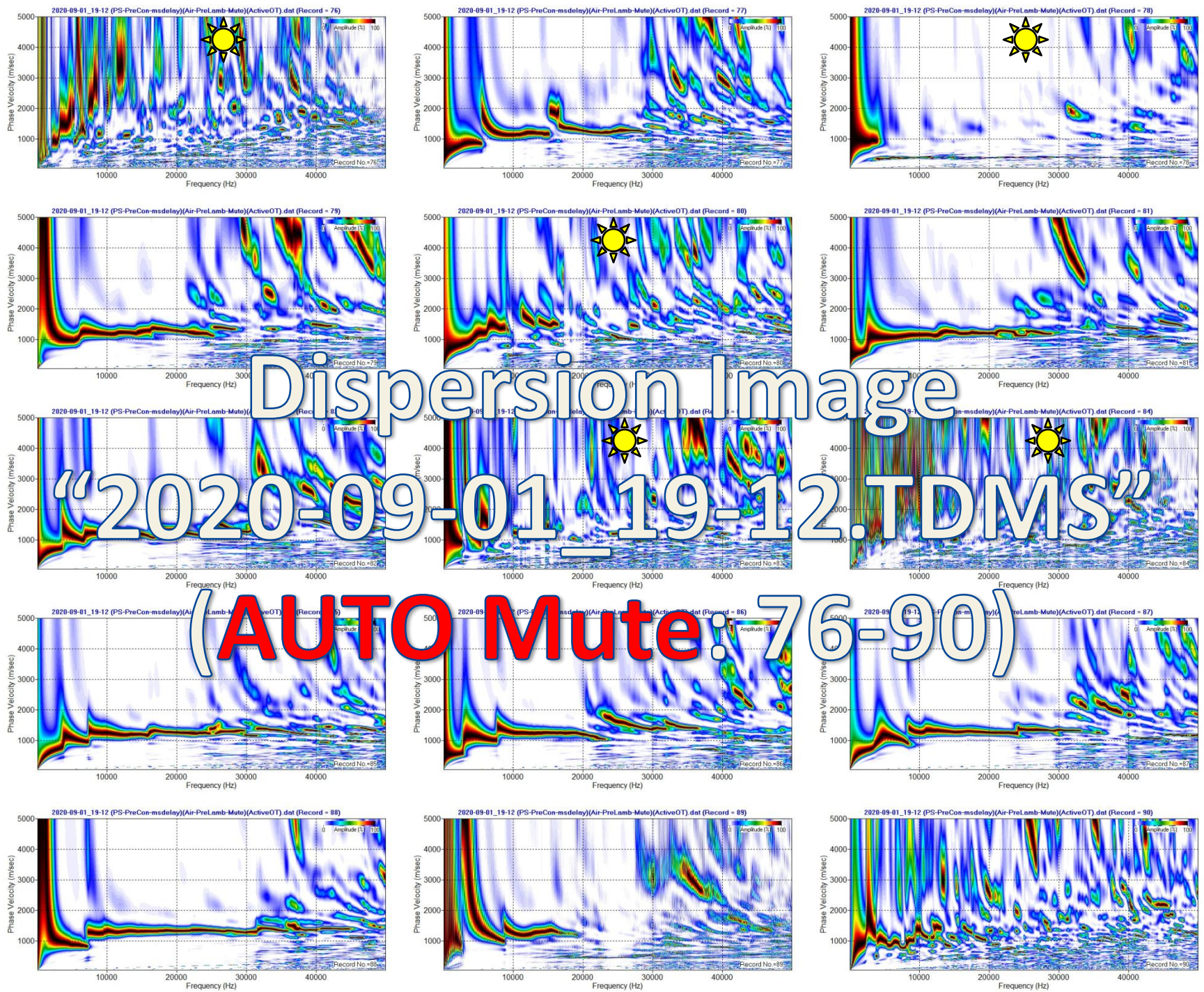

Dispersion Image

“2020-09-01_19-12.TDMS”

(AUTO Mute: 76-90)

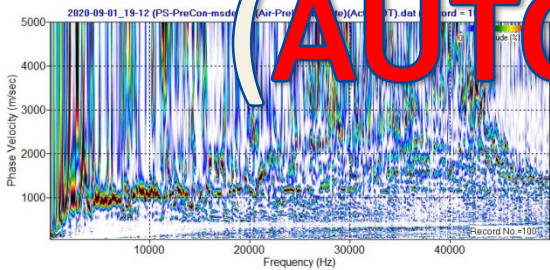
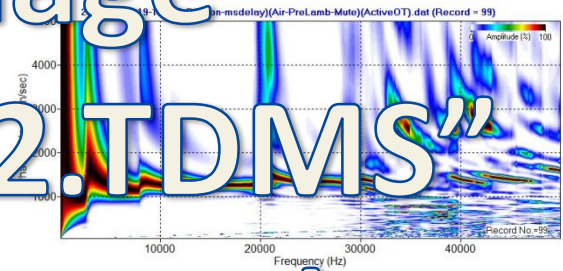
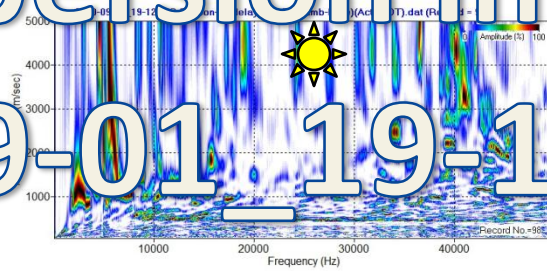
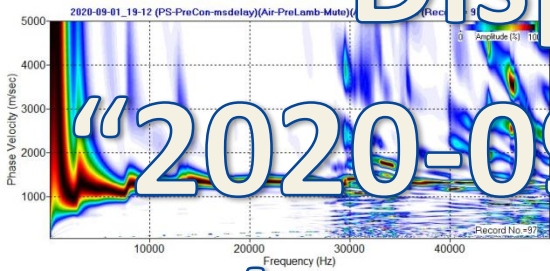
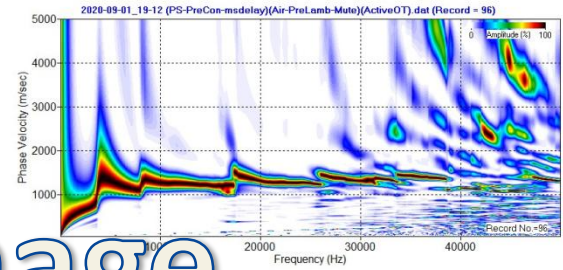
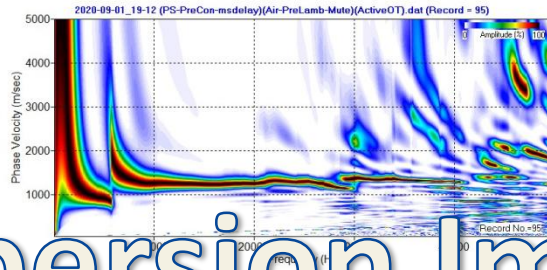
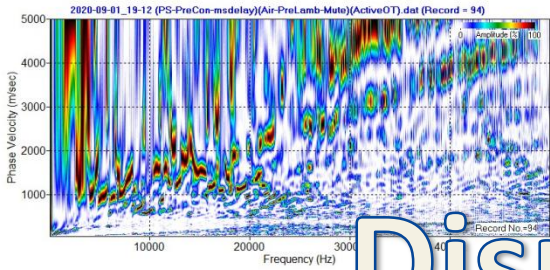
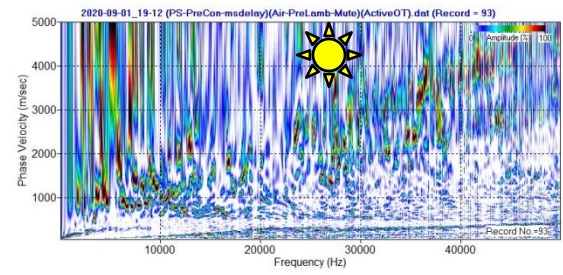
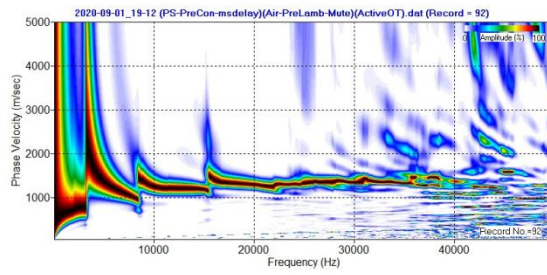
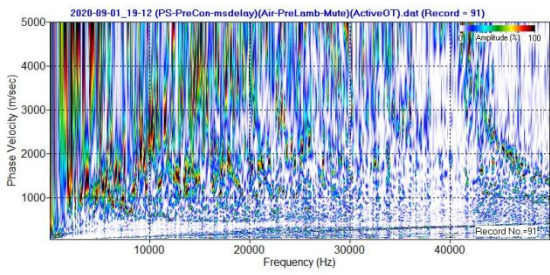

Dispersion Image

“2020-09-01_19-12.TDMS”

(AUTO Mute: 91-100)

Data (September 1, 2020)

- **“2020-09-01_19-24.TDMS”**
 - Total 50 records of 48-channel records from forward shots
 - 0.5-ms Pre-trigger time

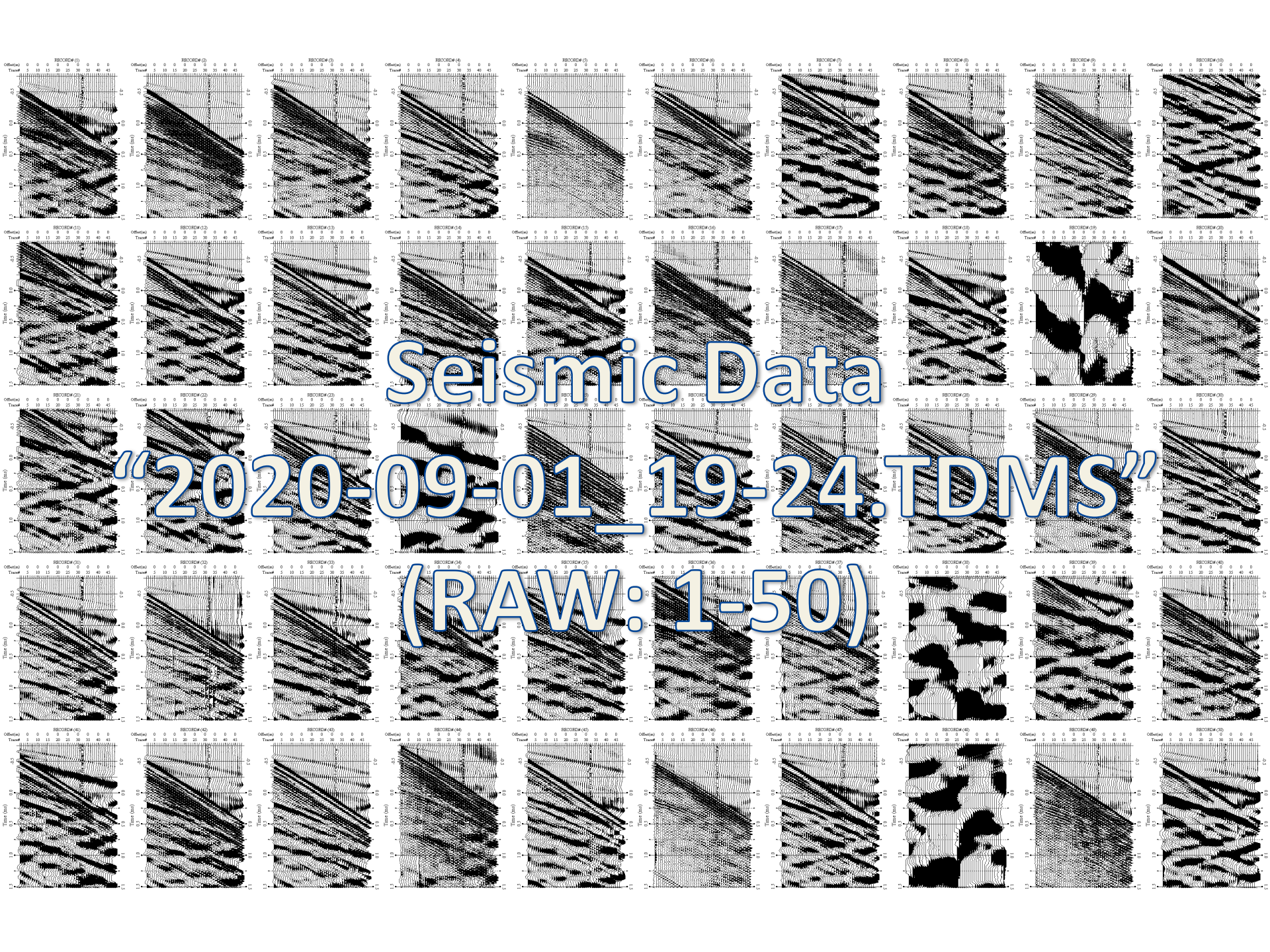

Seismic Data

“2020-09-01_19-24.TDMS”

(RAW: 1-50)

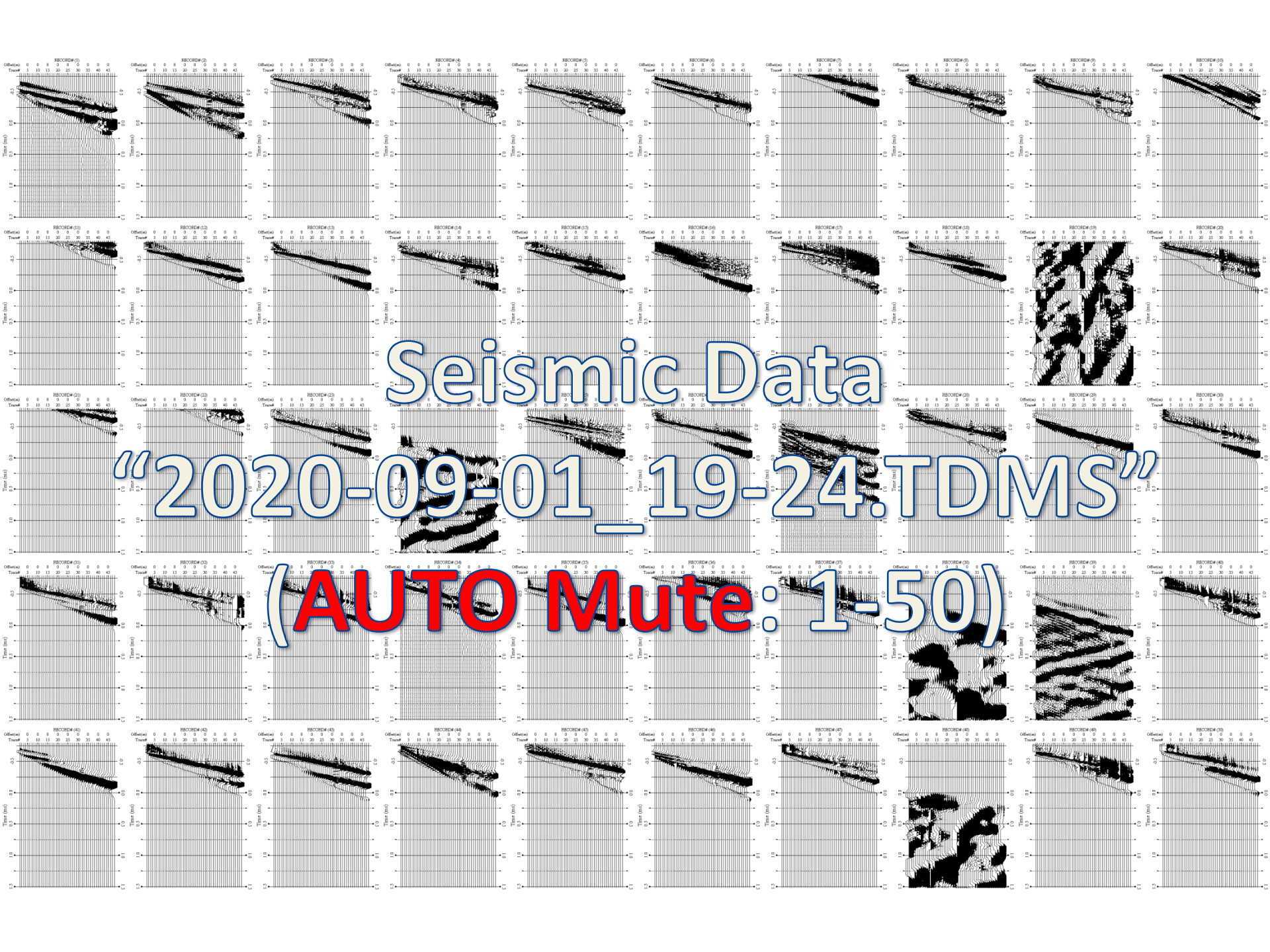

Seismic Data

“2020-09-01_19-24.TDMS”

(AUTO Mute: 1-50)

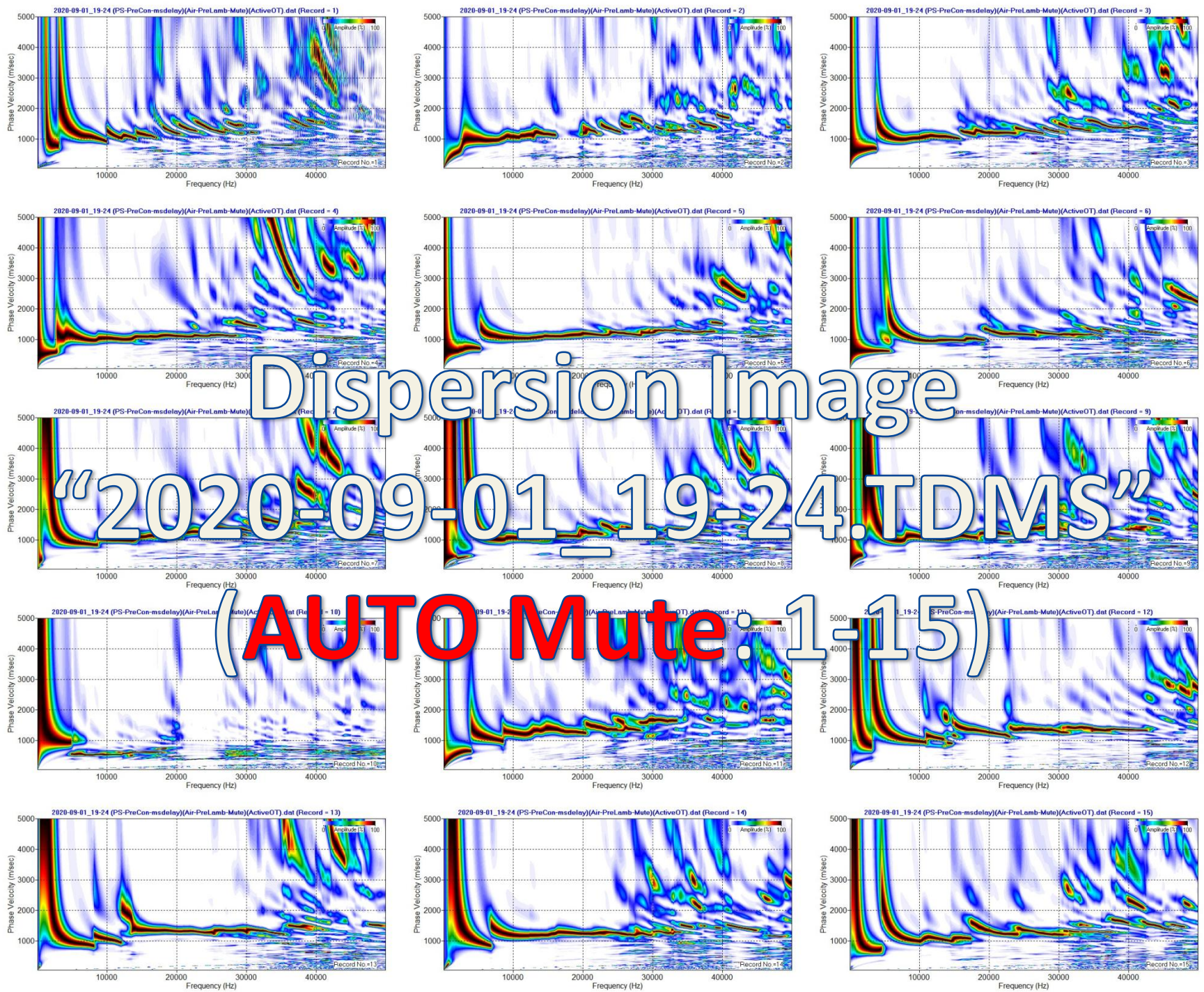

Dispersion Image

“2020-09-01_19-24.TDMS”

(AUTO Mute: 1-15)

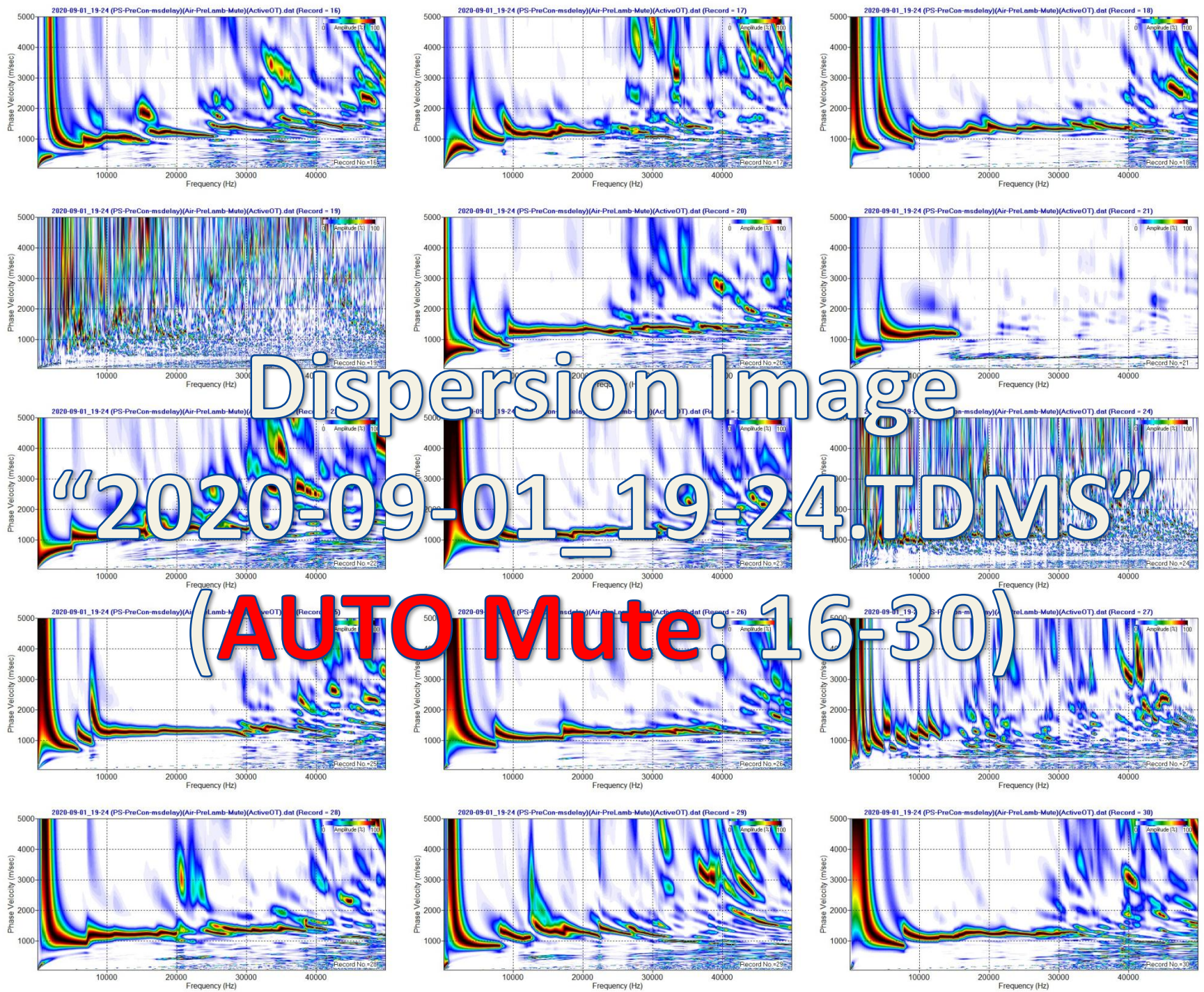

Dispersion Image

"2020-09-01_19-24.TDMS"

(AUTO Mute: 16-30)

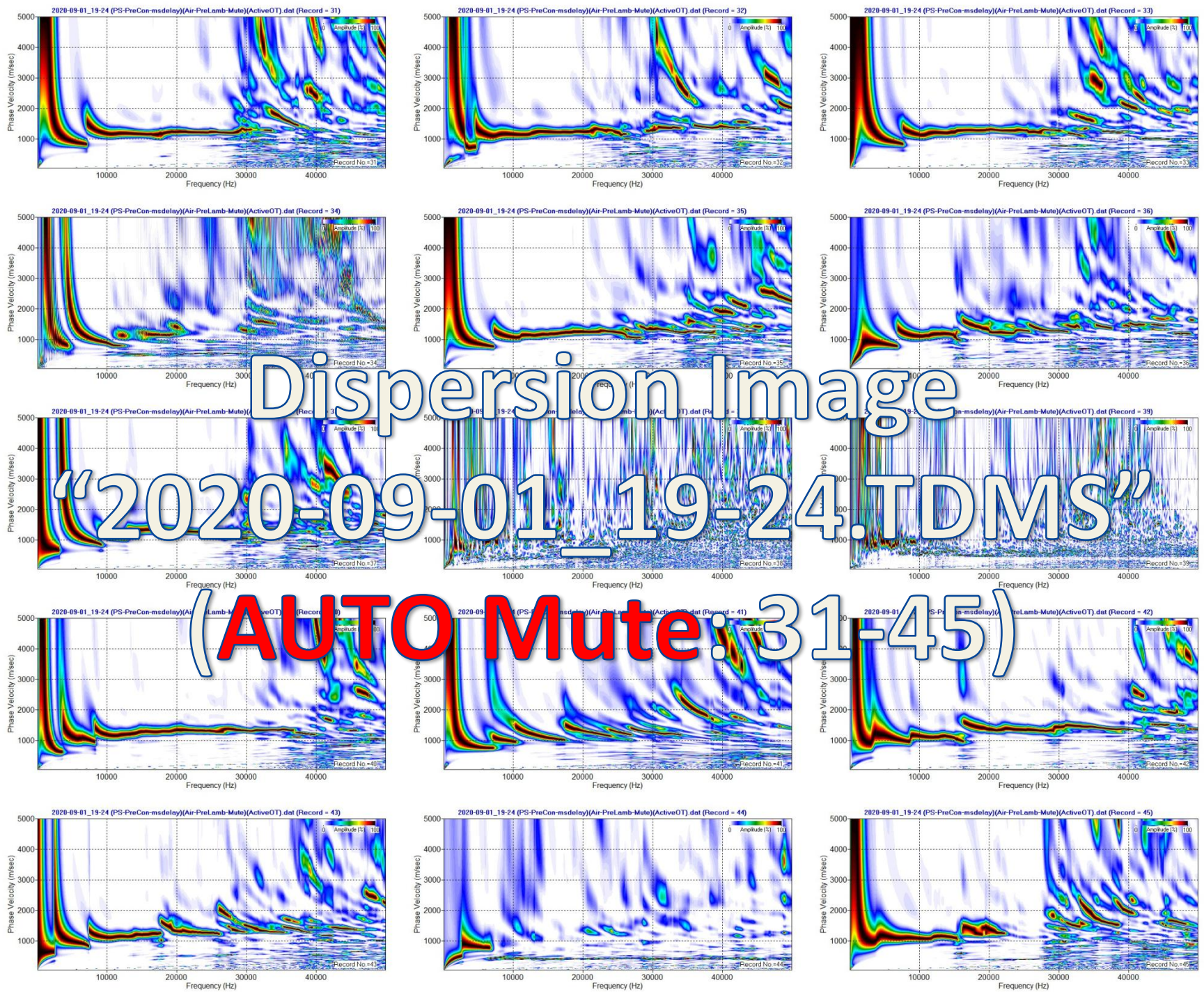

Dispersion Image

“2020-09-01_19-24.TDMS”

(AUTO Mute: 31-45)

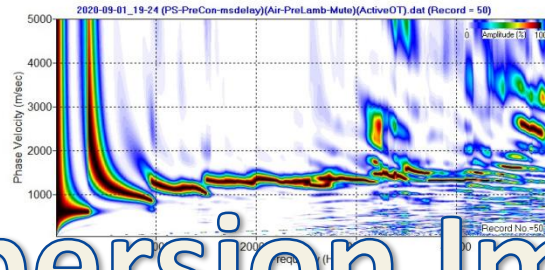
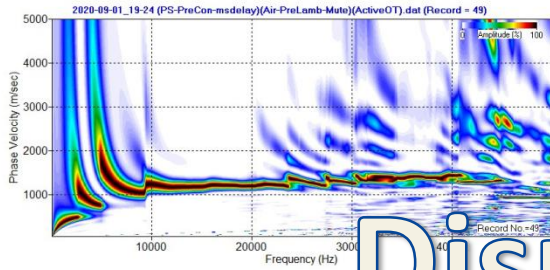
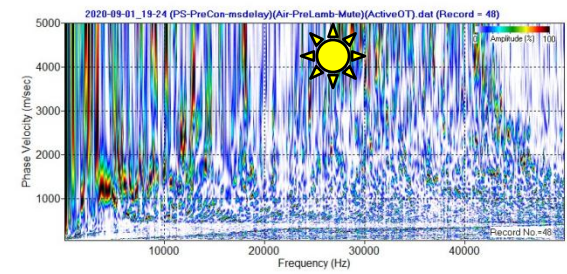
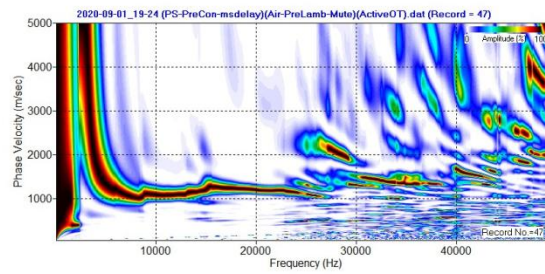
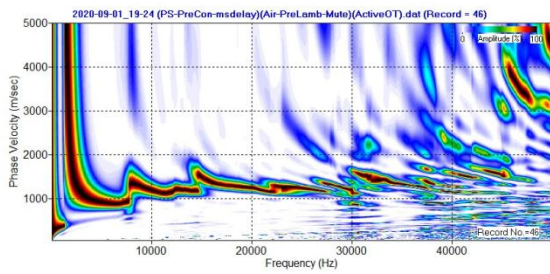

Dispersion Image

“2020-09-01_19-24.TDMS”

(**AUTO Mute**: 46-50)

Test of Optimum Channel Configuration for 1D Array

- Full (48) channel record and spatially resampled 16-channel record of 3dx are compared in dispersion image.
- A 16-channel configuration of the original receiver spacing (dx) is tested for different offset ranges, i.e., near, middle, and far offsets, to examine whether there is any advantage or not.
- A simple resampling (3dx) is compared to the stack-resampling (3dx-stk) for possible difference.

48-CH (dx) vs. 16-CH (3dx)

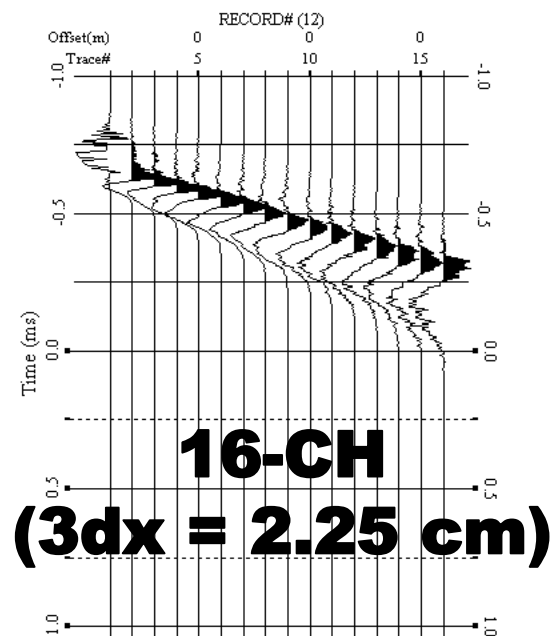
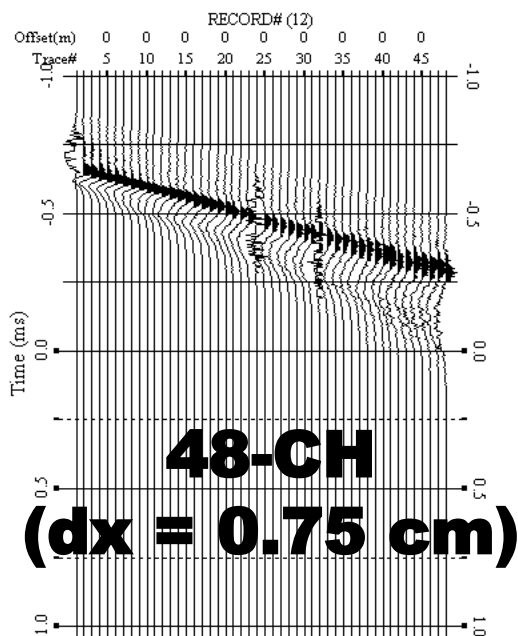

I20-08-12_11-37_0000(PreCon)(HeadEdit)(AUTO-Air-PreLamb-Mute)(12)(ActiveOT).dat (

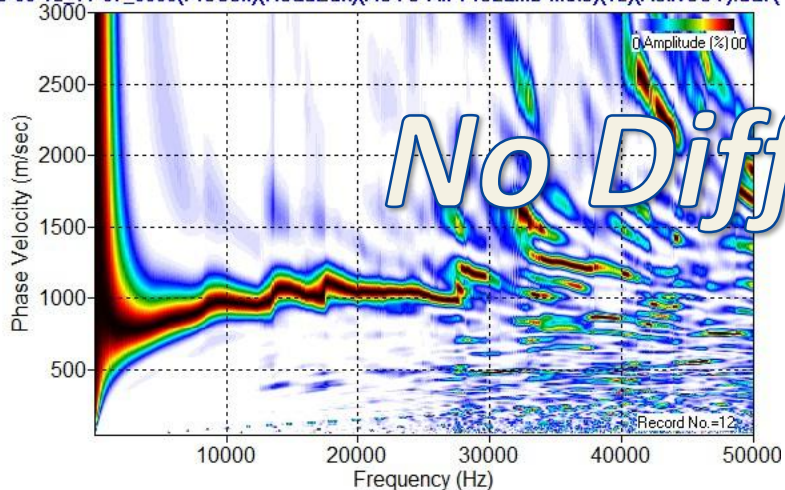

I-08-12_11-37_0000(PreCon)(HeadEdit)(AUTO-Air-PreLamb-Mute)(12)(3dx)(ActiveOT).de

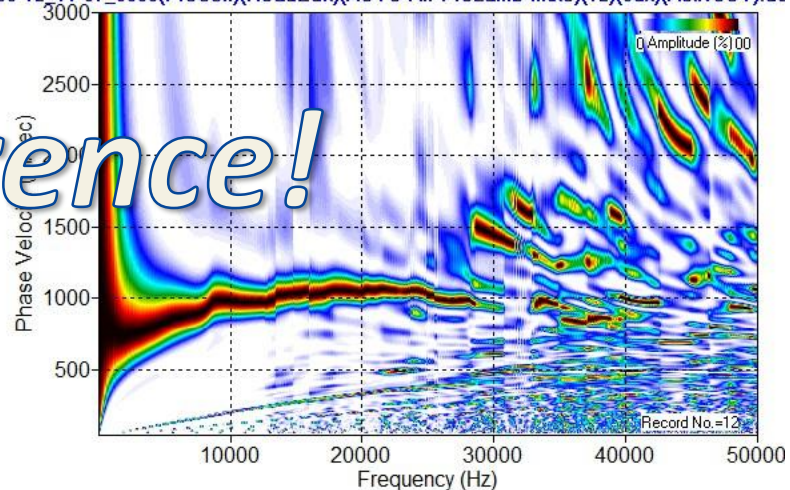

No Difference!

16-CH (dx) at Different Offsets

16-CH (dx = 0.75 cm)

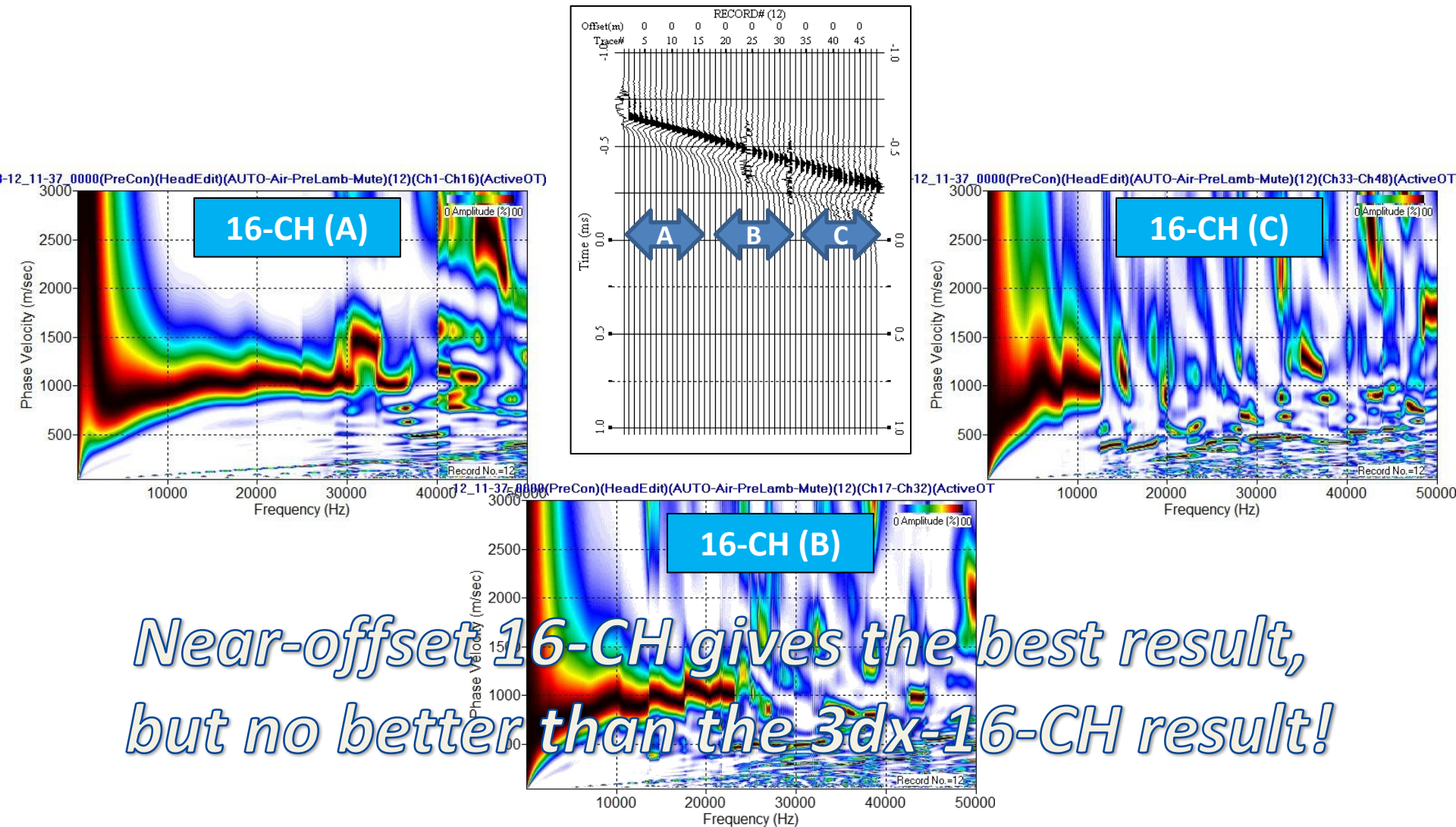

Near-offset 16-CH gives the best result, but no better than the 3dx-16-CH result!

Simple vs. Stack Resampling (16-CH)

**Simple
Resampling
(3dx)**

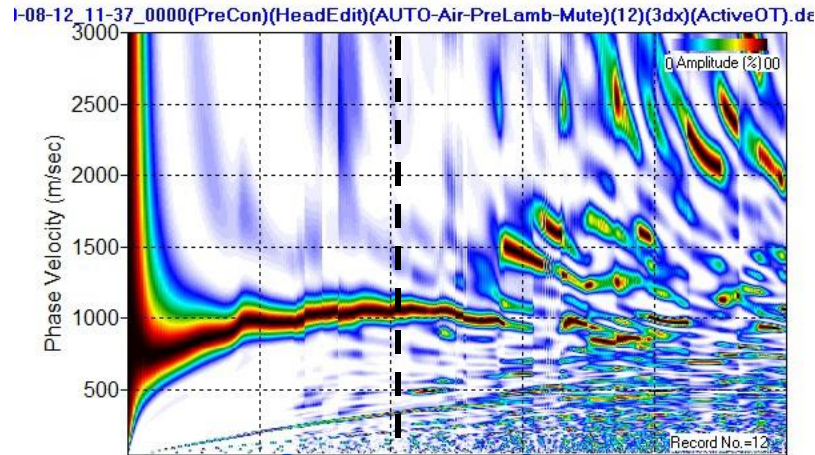

The stack resampling (3dx-stk) results in attenuation of high frequencies due to the smearing effect!

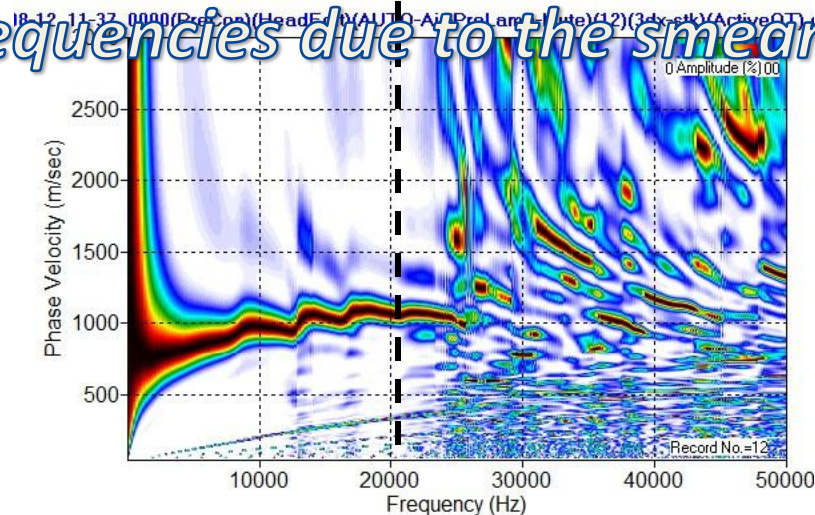

**Stack
Resampling
(3dx-stk)**

Data (September 1, 2020)

- Dispersion Images - “2020-09-01_19-12.TDMS”
 - Total 100 records of originally 48-channel records spatially resampled to make records of 3 times (3dx) the original receiver spacing (dx) (**i.e., “3dx-16-channel” records**).
 - Compared to the original (48-channel) records’ dispersion images

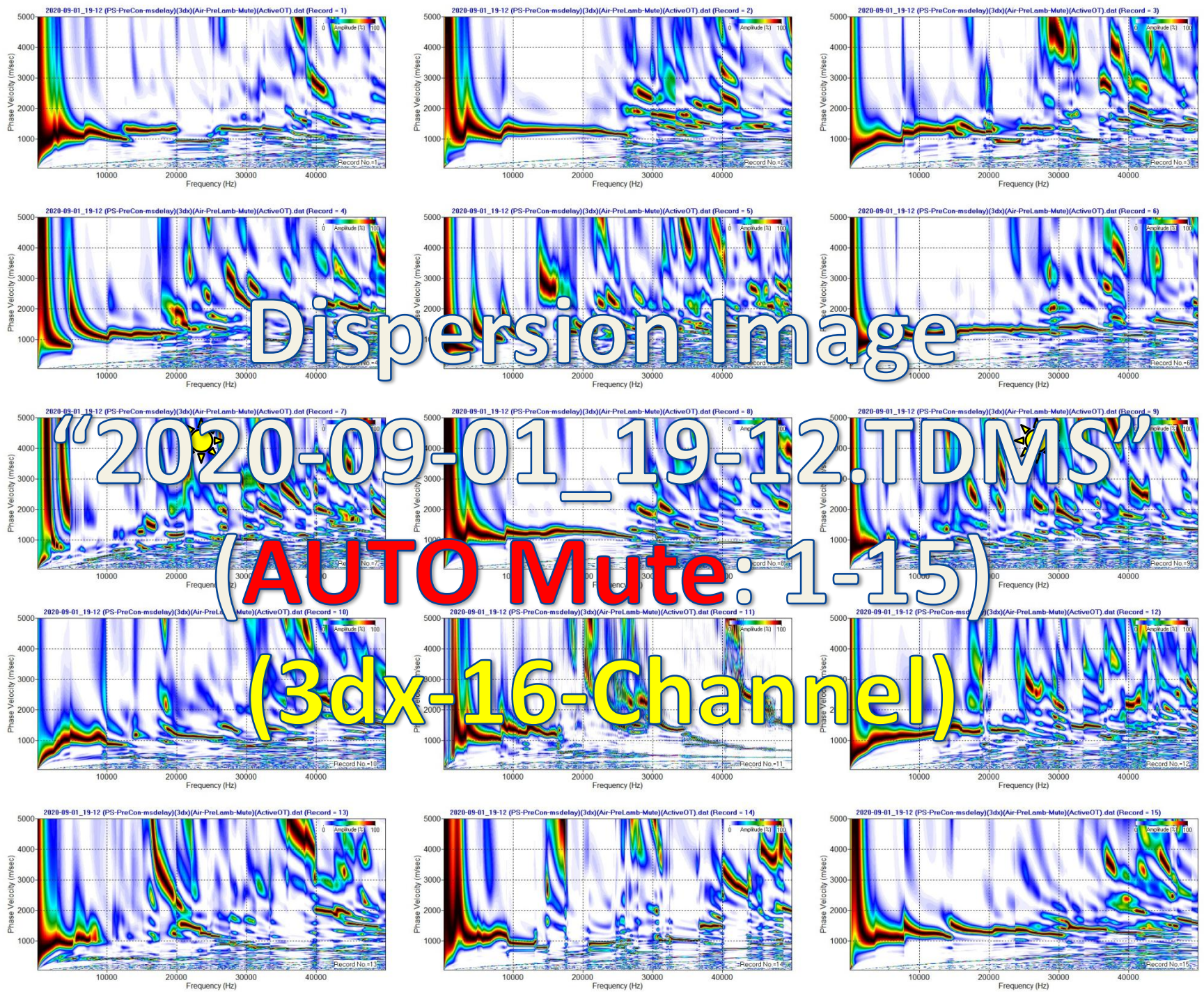

Dispersion Image

“2020-09-01_19-12.TDMS”

(AUTO Mute: 1-15)

(3dx-16-Channel)

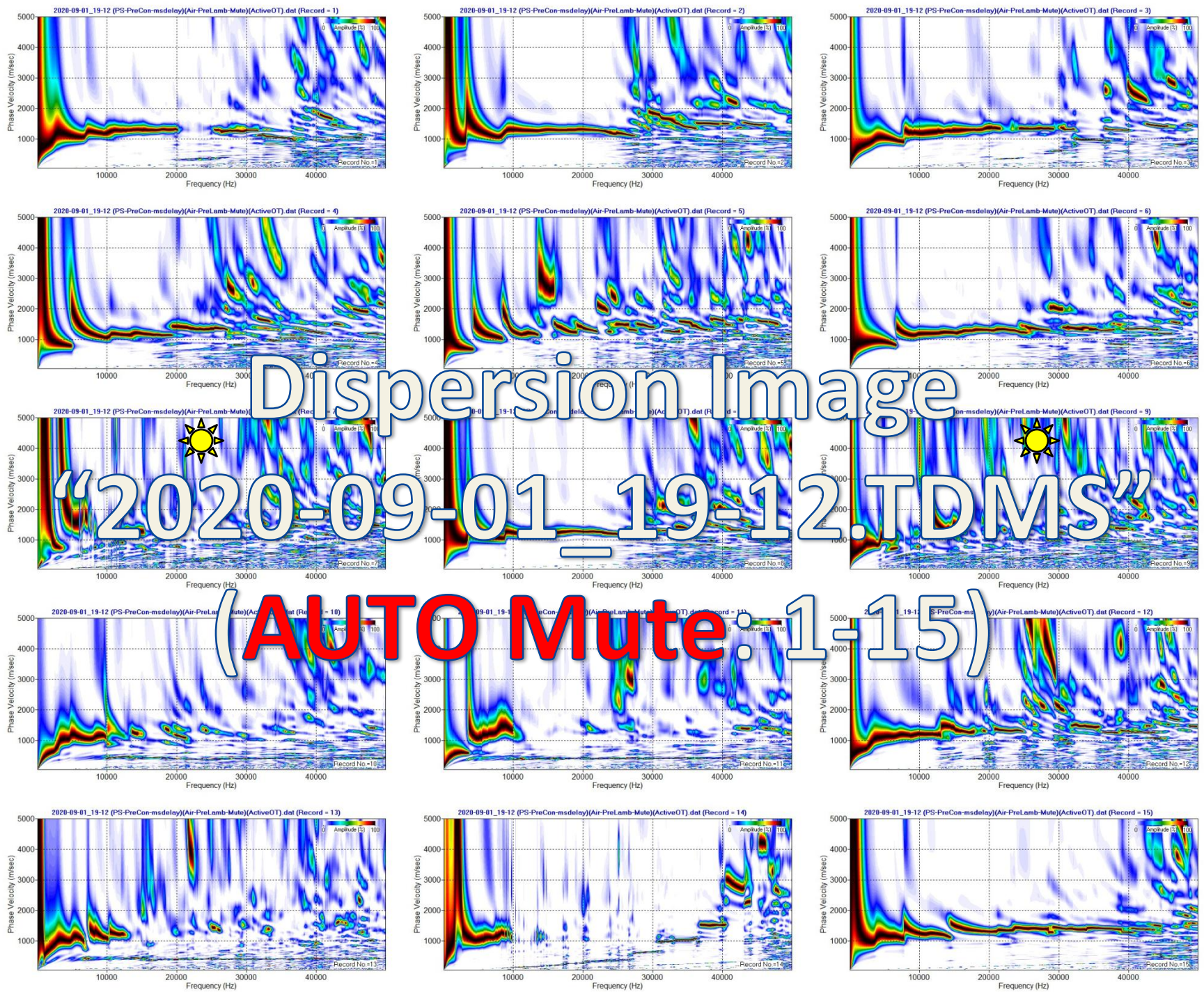

Dispersion Image

“2020-09-01_19-12.TDMS”

(AUTO Mute: 1-15)

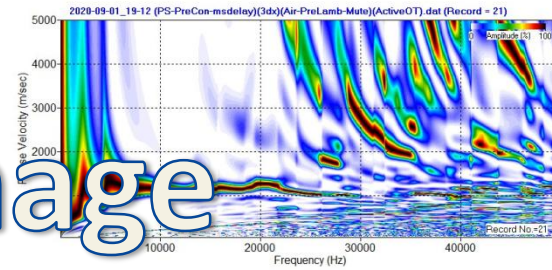
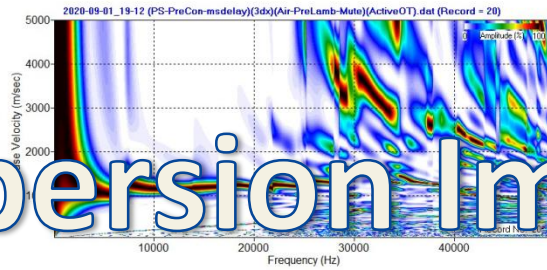
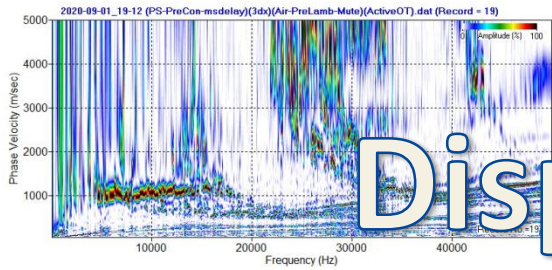
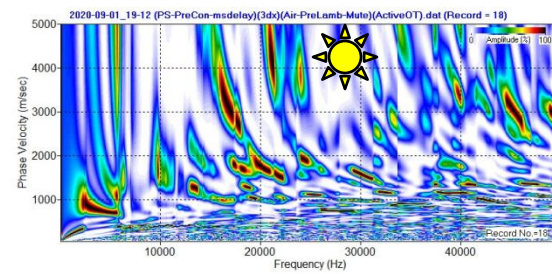
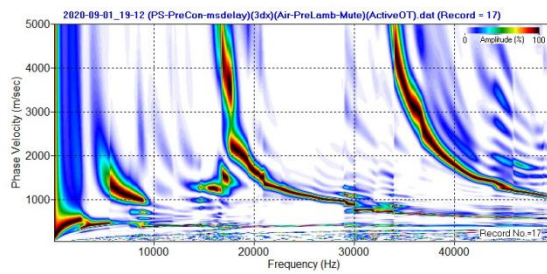
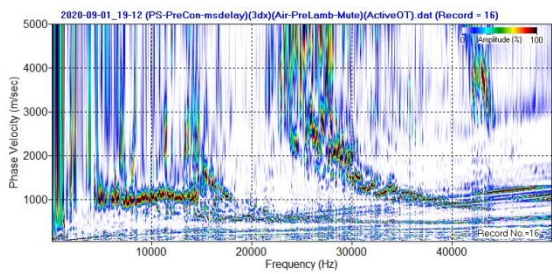

Dispersion Image

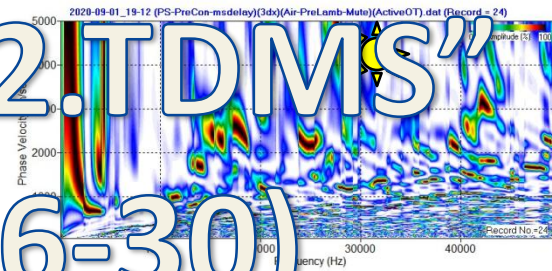
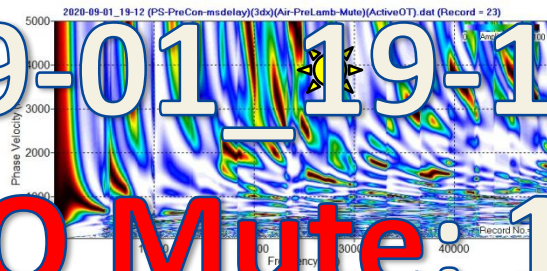
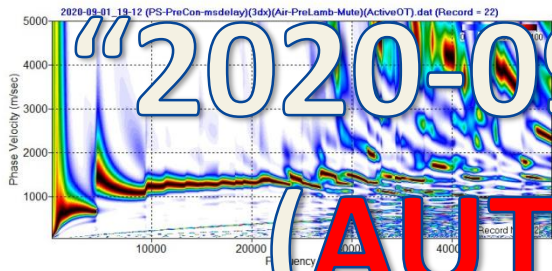

"2020-09-01_19-12.TDMS"

(AUTO Mute: 16-30)

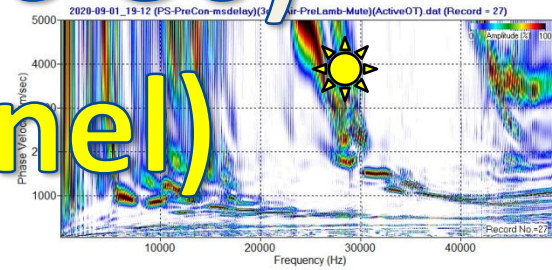
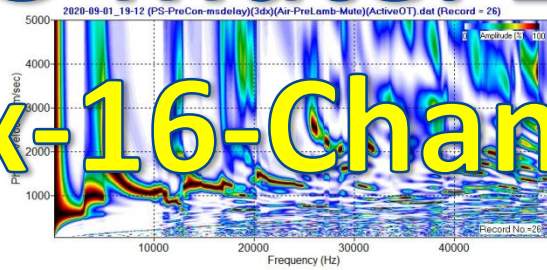
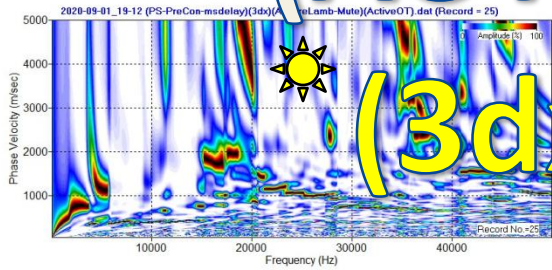

(3dx-16-Channel)

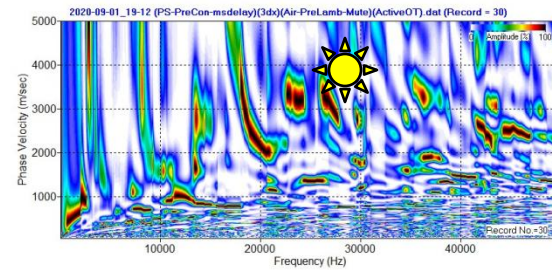
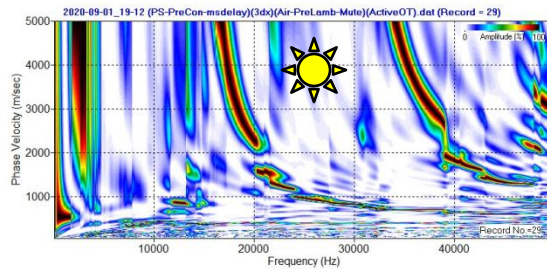
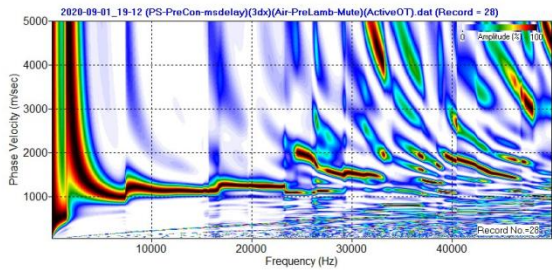

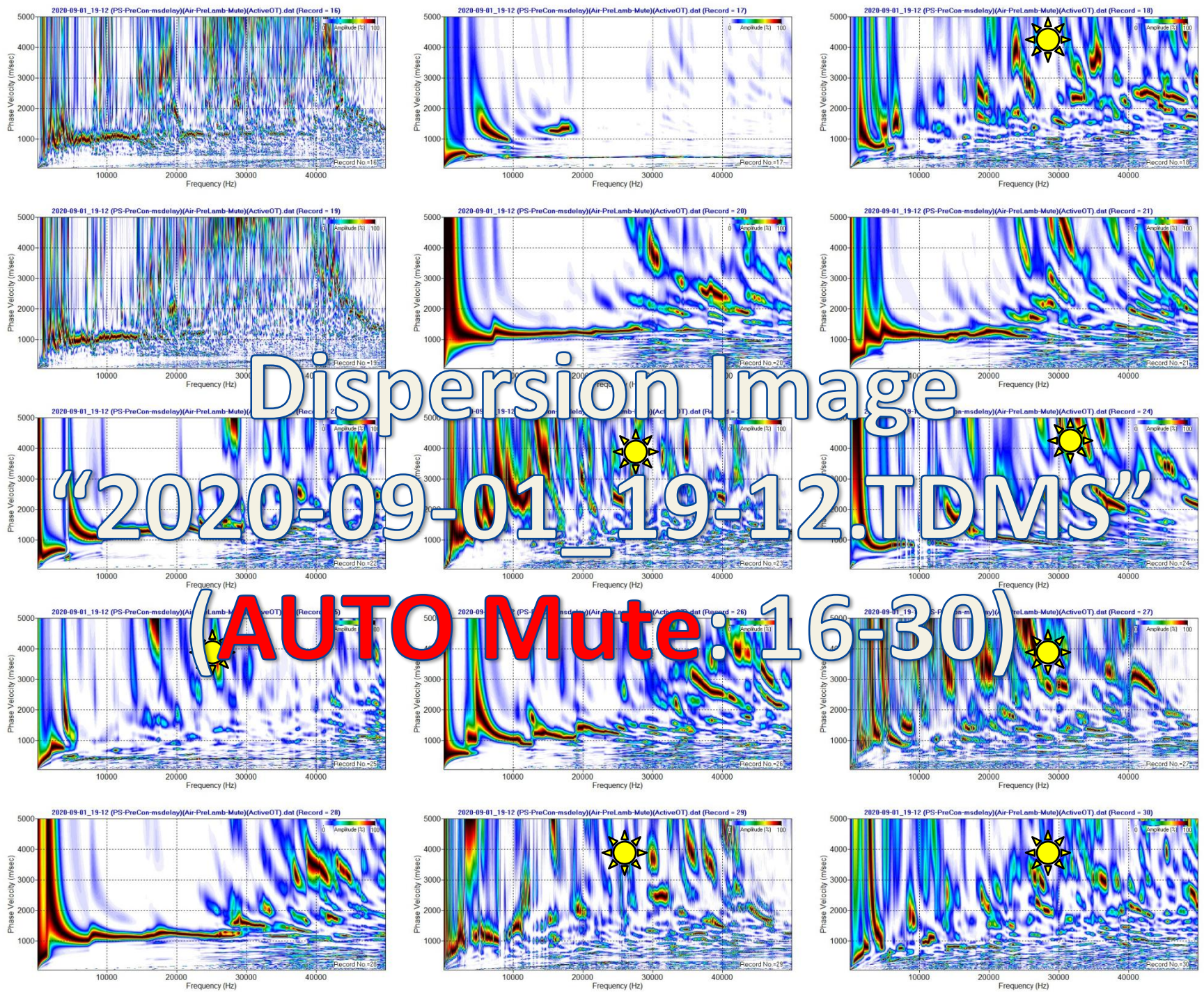

Dispersion Image

“2020-09-01_19-12.TDMS”

(AUTO Mute: 16-30)

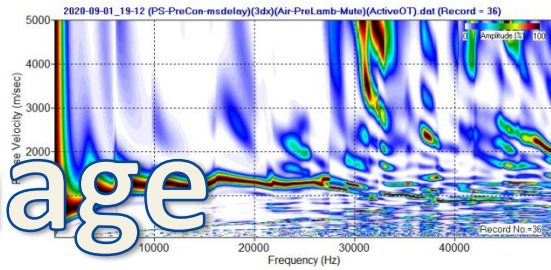
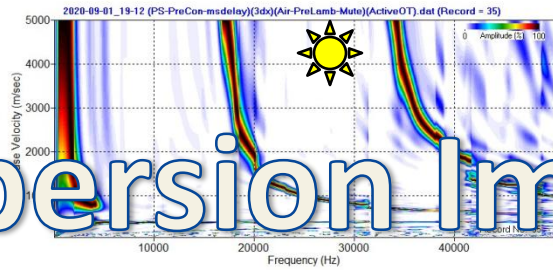
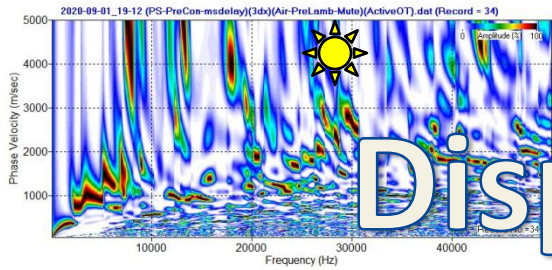
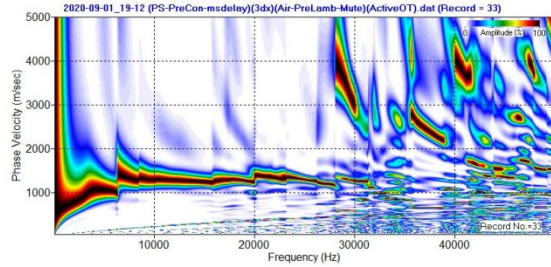
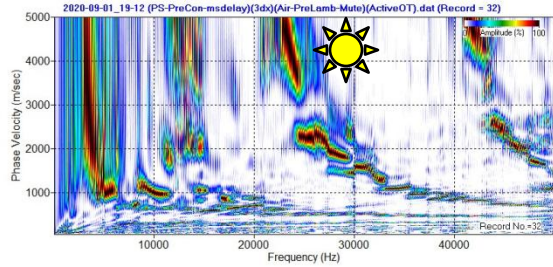
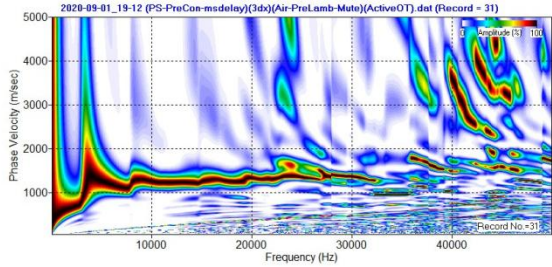

Dispersion Image

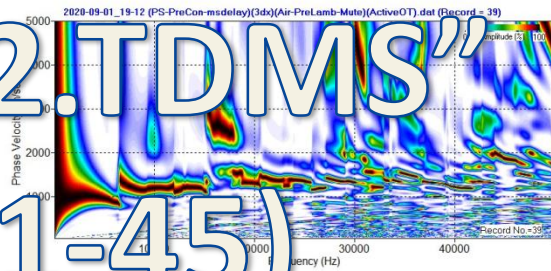
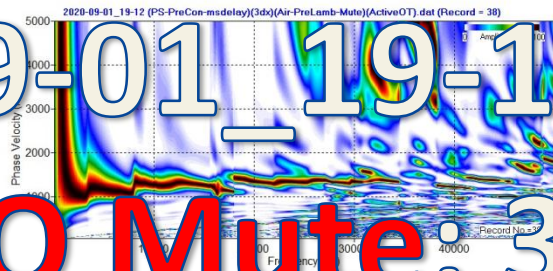
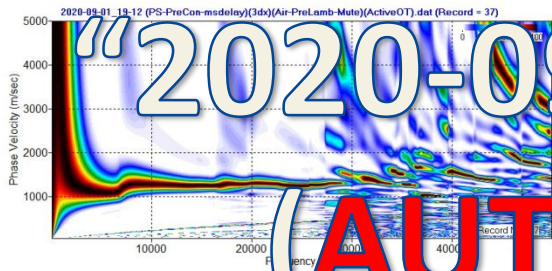

"2020-09-01_19-12.TDMS"

(AUTO Mute: 31-45)

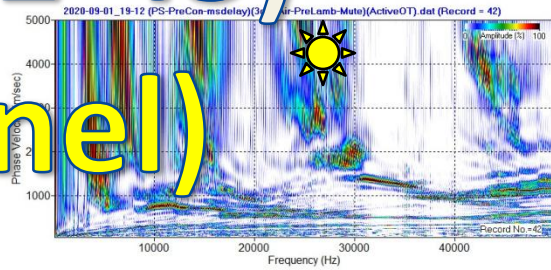
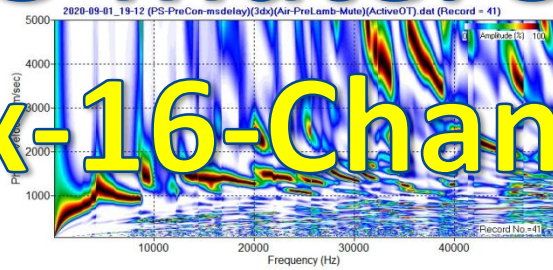
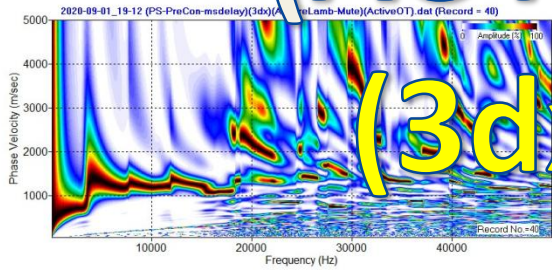

(3dx-16-Channel)

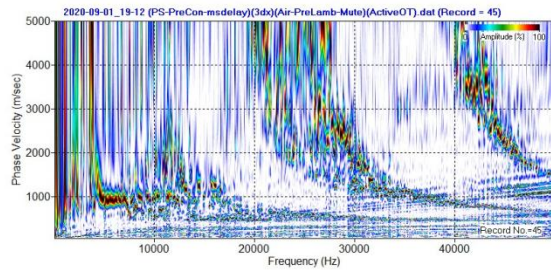
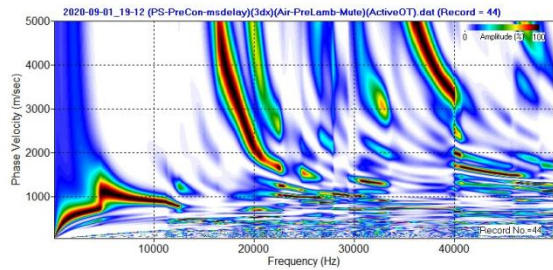
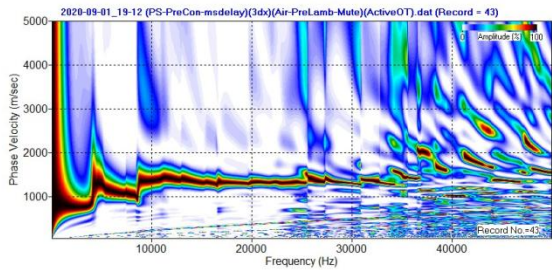

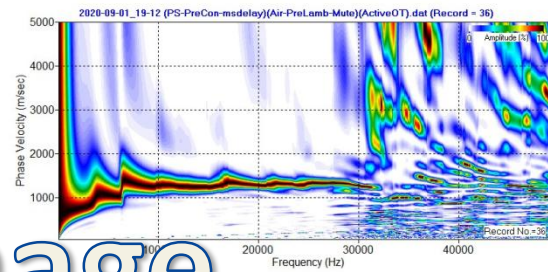
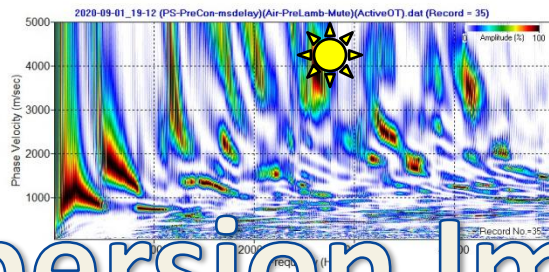
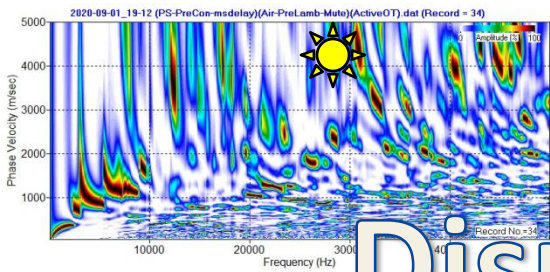
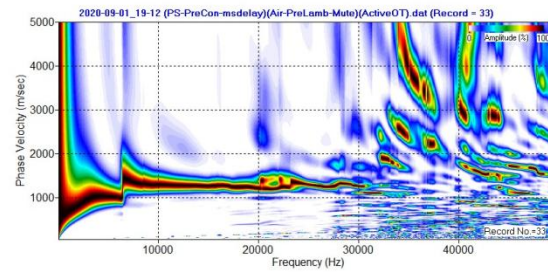
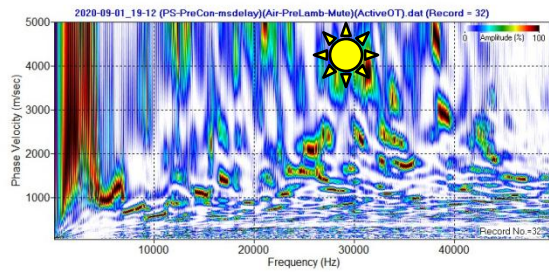
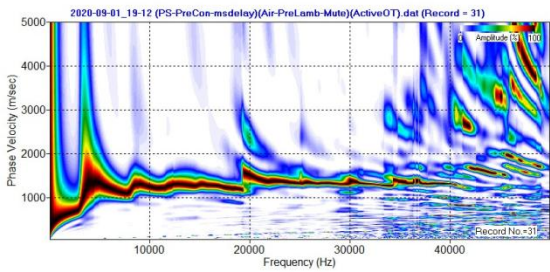

Dispersion Image

"2020-09-01_19-12.TDMS"

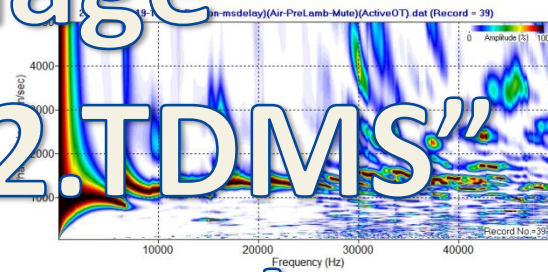
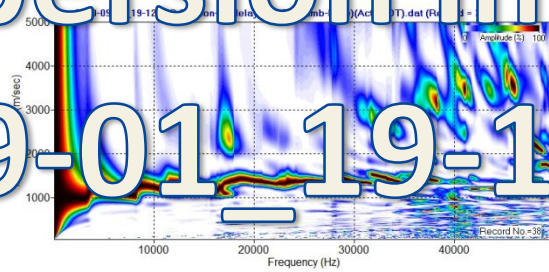
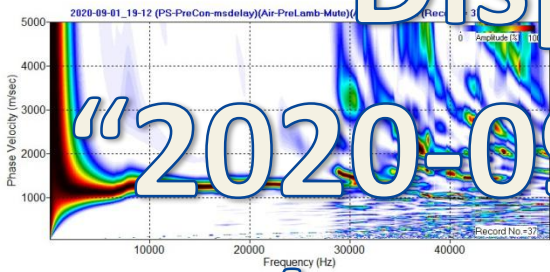

(AUTO Mute: 31-45)

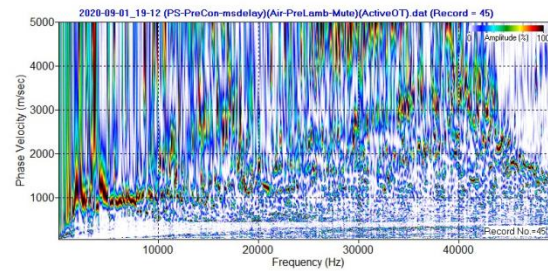
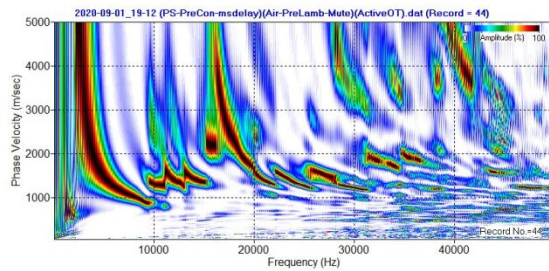
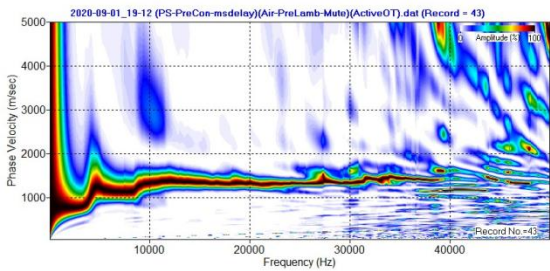
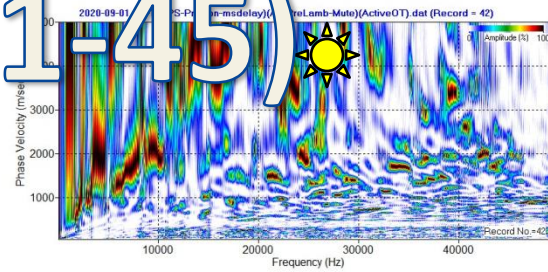
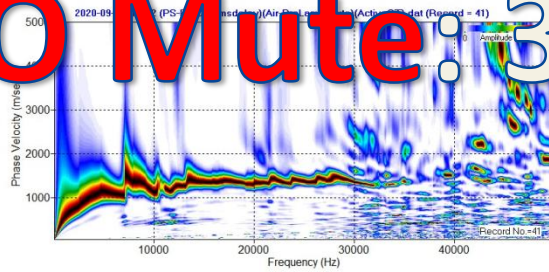
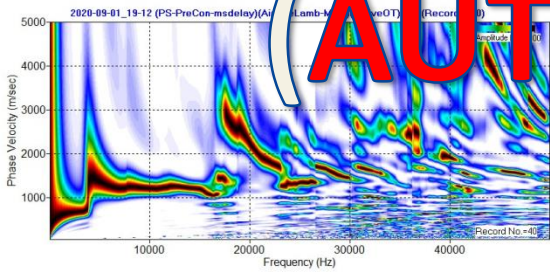

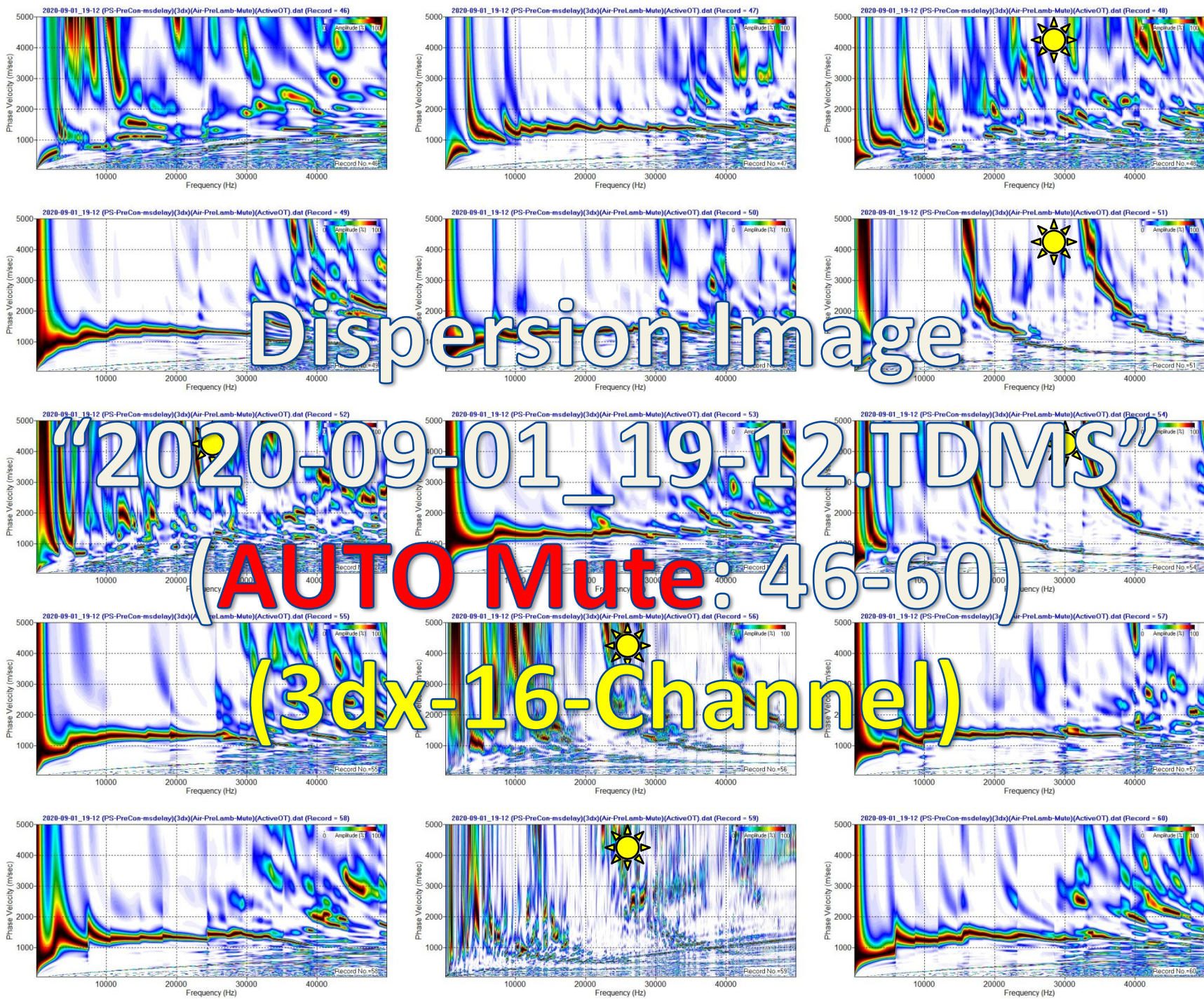

Dispersion Image

“2020-09-01_19-12.TDMS”

(AUTO Mute: 46-60)

(3dx-16-Channel)

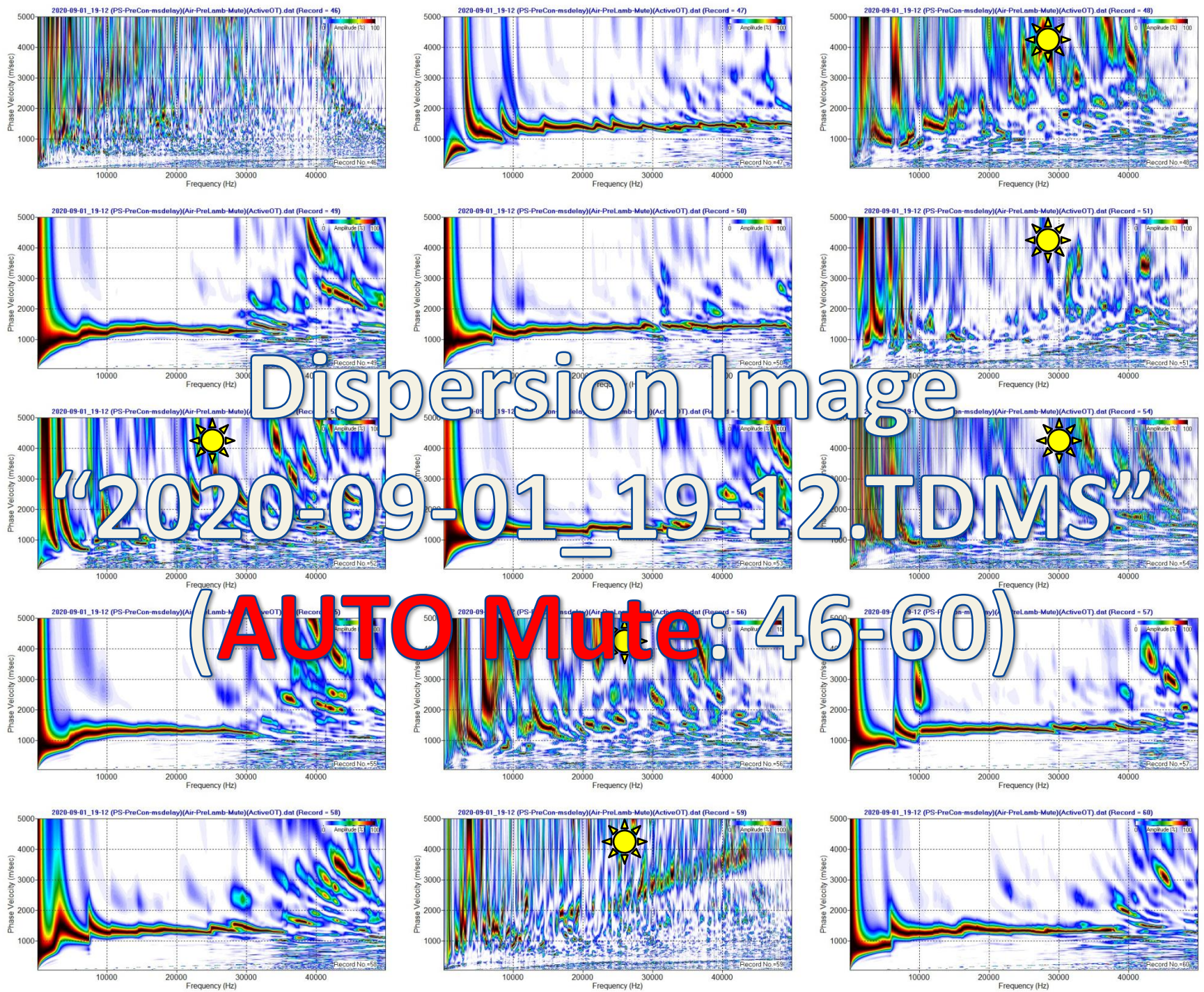

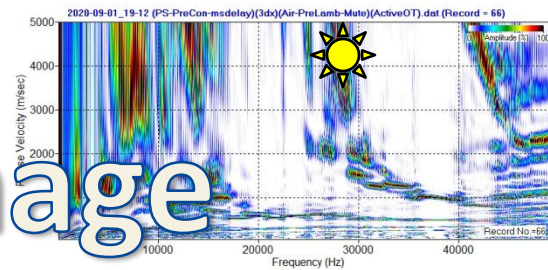
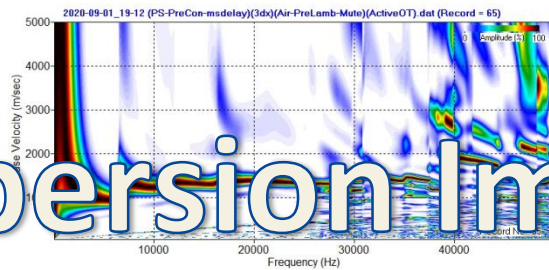
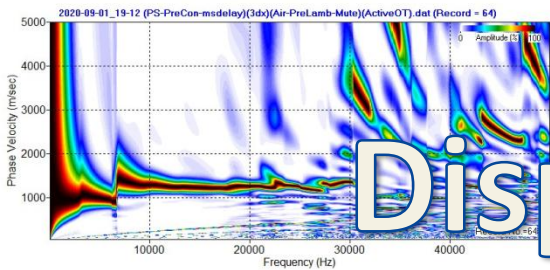
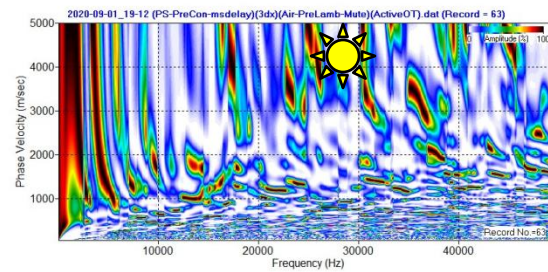
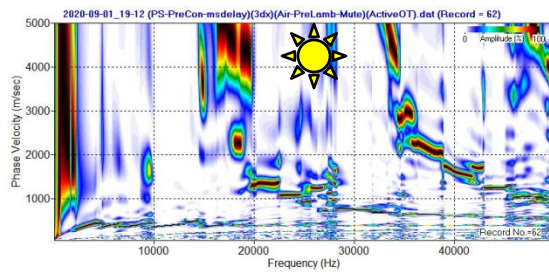
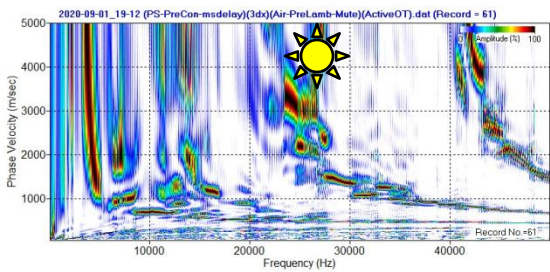

Dispersion Image

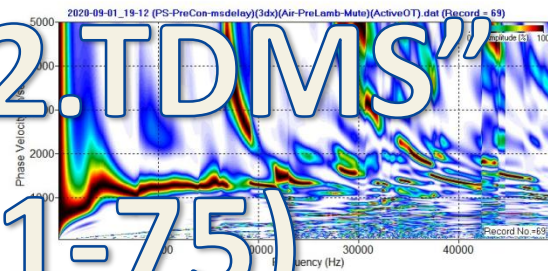
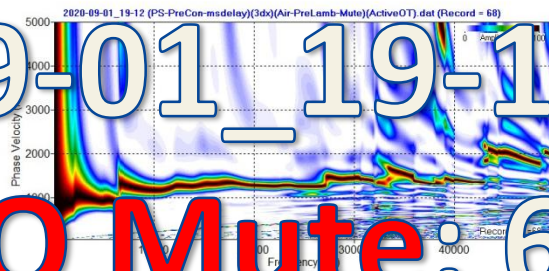
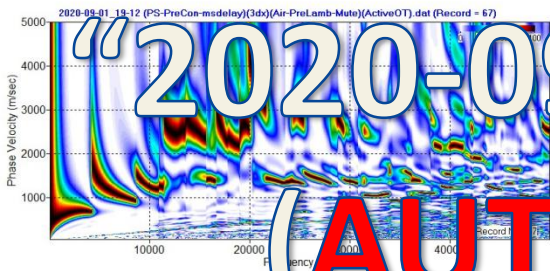

“2020-09-01_19-12.TDMS”

(AUTO Mute: 61-75)

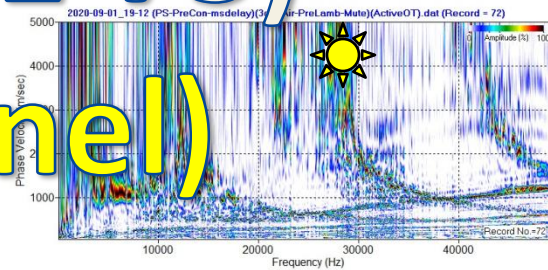
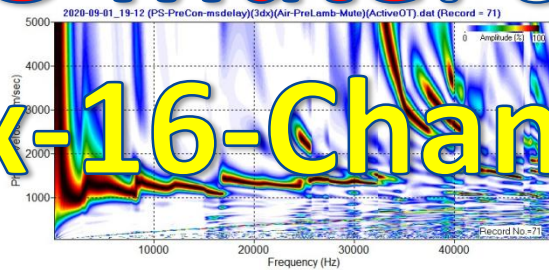
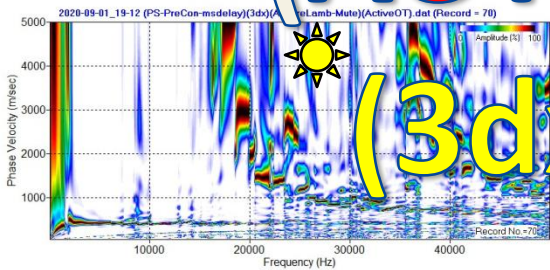

(3dx-16-Channel)

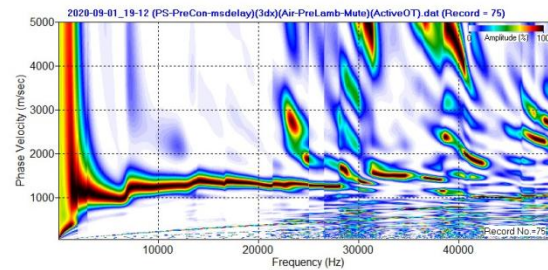
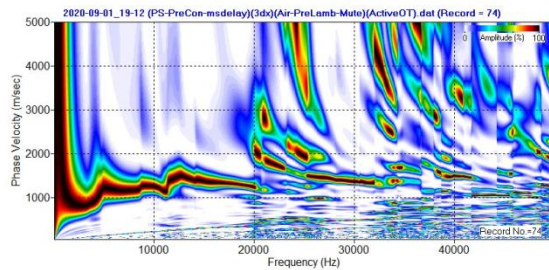
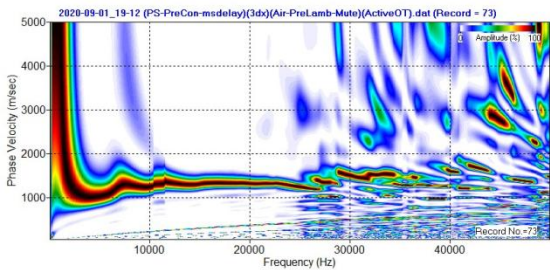

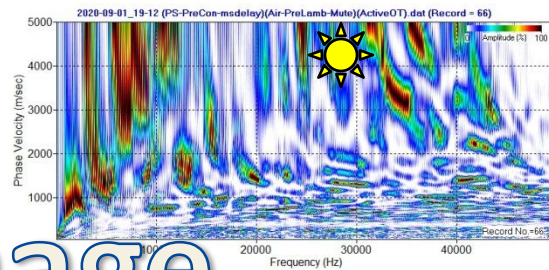
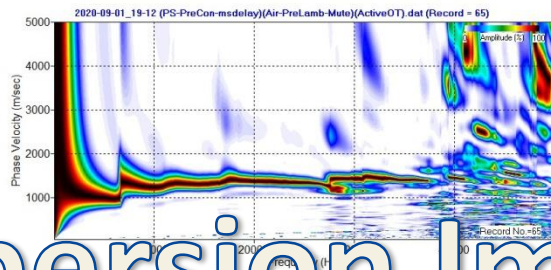
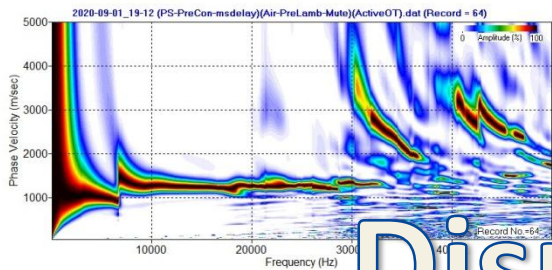
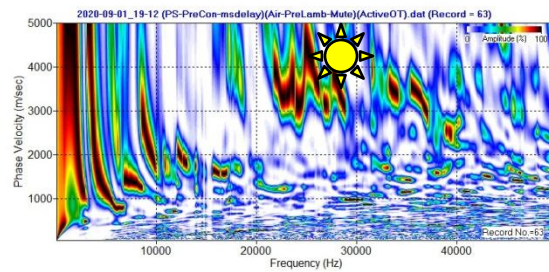
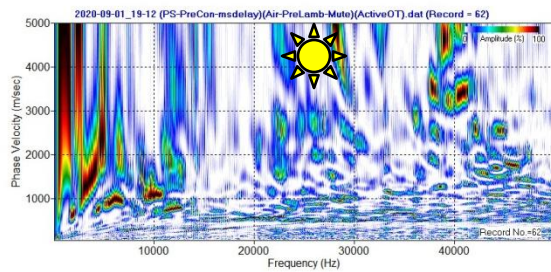
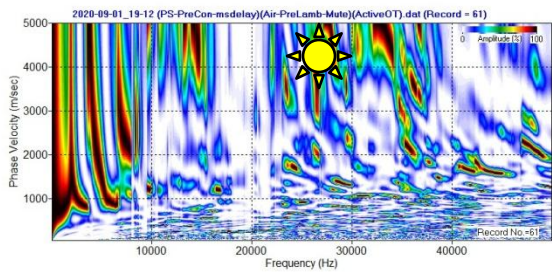

Dispersion Image

“2020-09-01_19-12.TDMS”

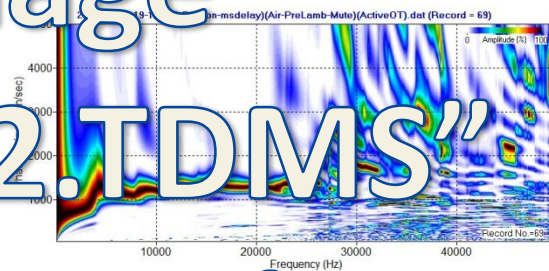
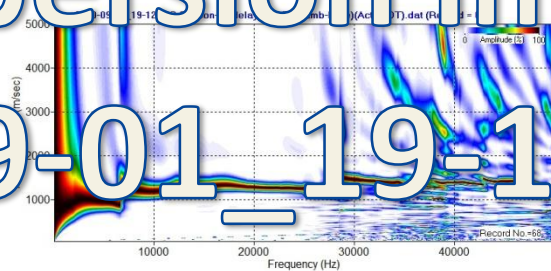
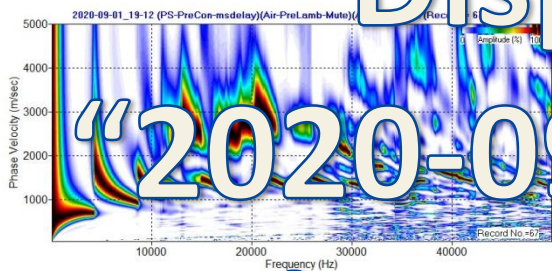

(AUTO Mute: 61-75)

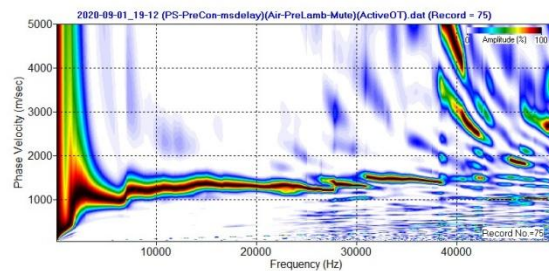
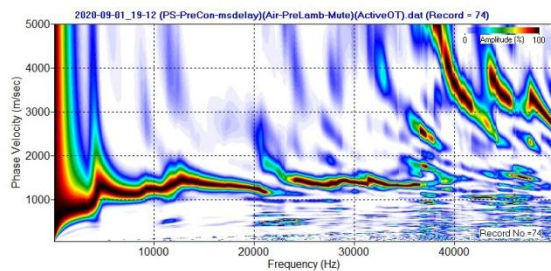
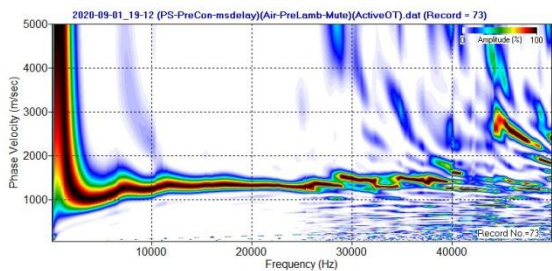
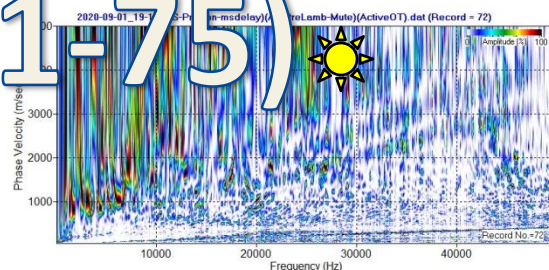
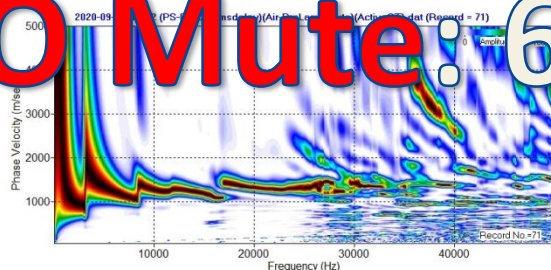
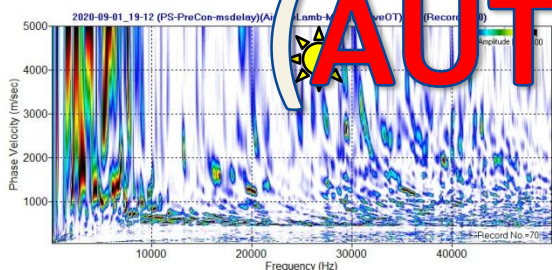

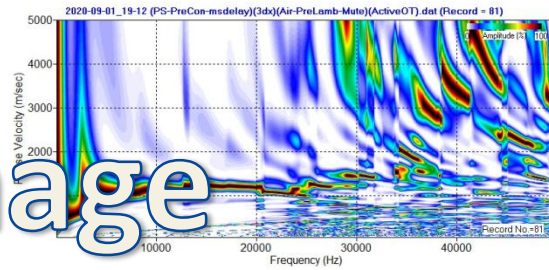
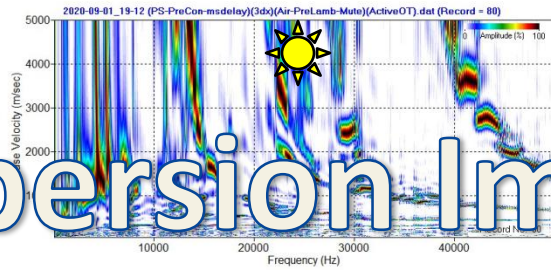
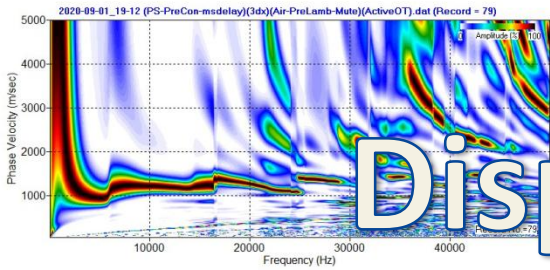
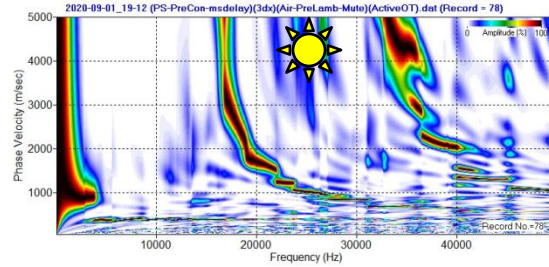
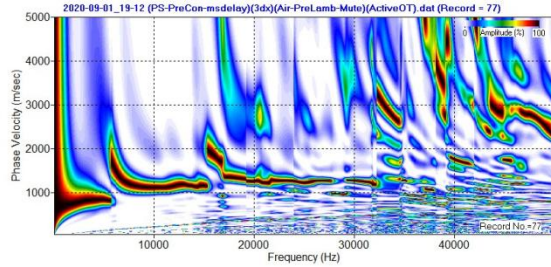
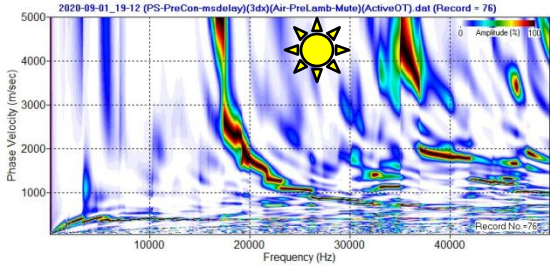

Dispersion Image

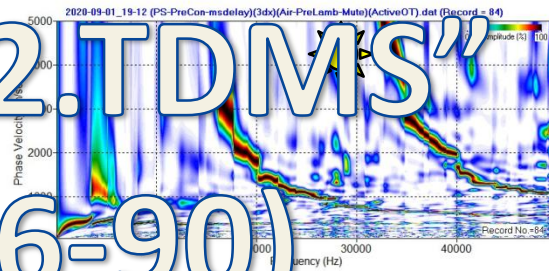
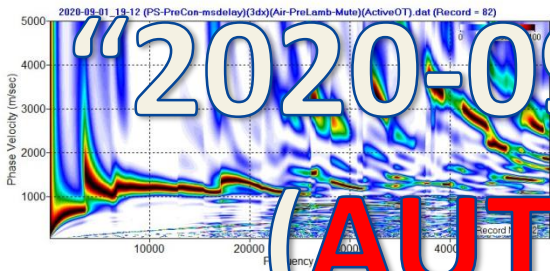

“2020-09-01_19-12.TDMS”

(AUTO Mute: 76-90)

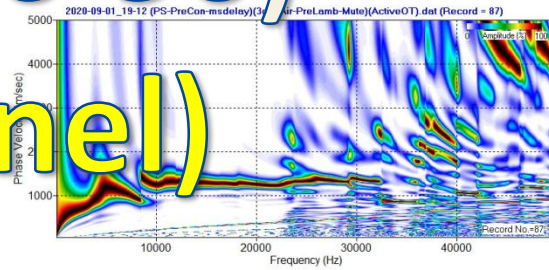
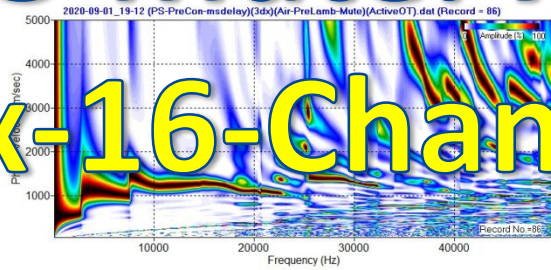
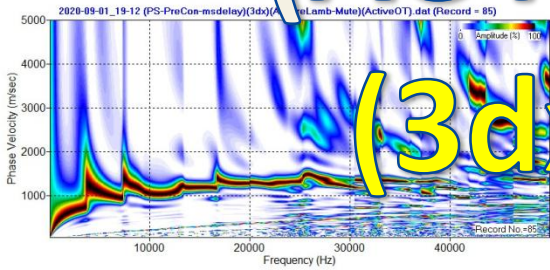

(3dx-16-Channel)

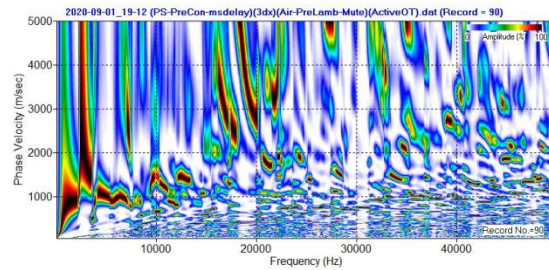
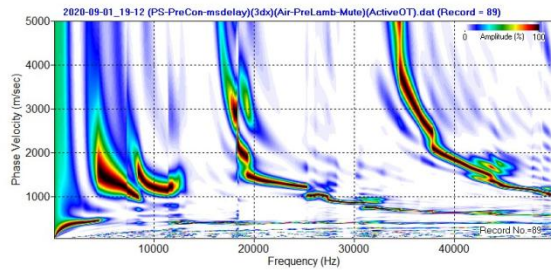
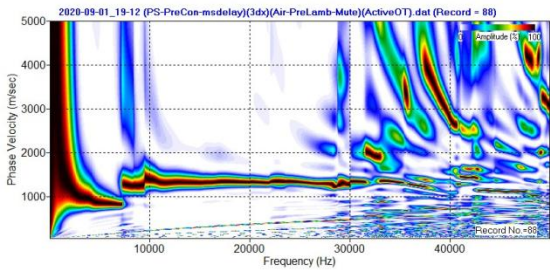

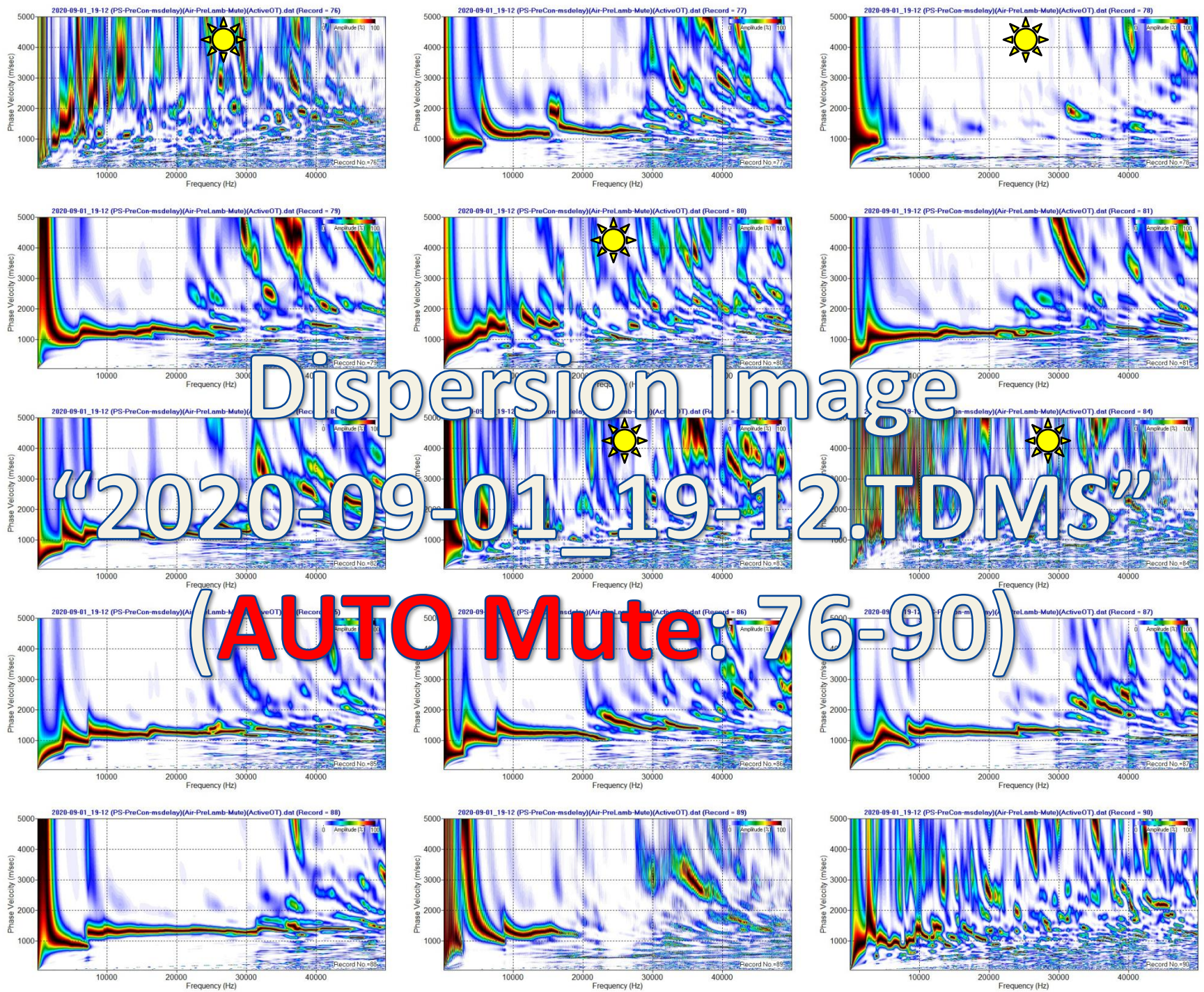

Dispersion Image

“2020-09-01_19-12.TDMS”

(AUTO Mute: 76-90)

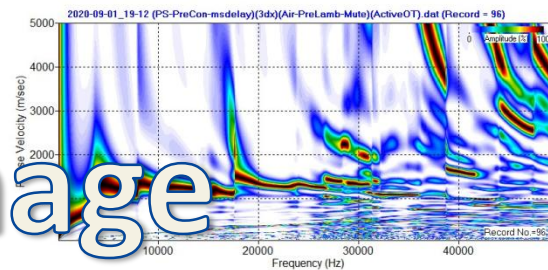
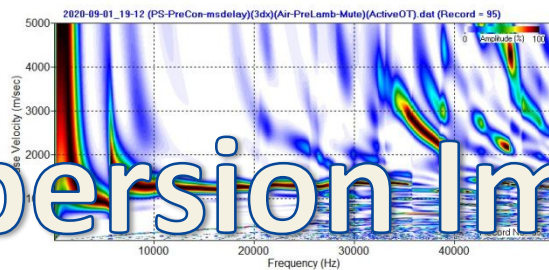
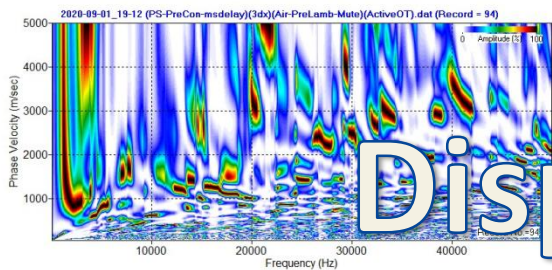
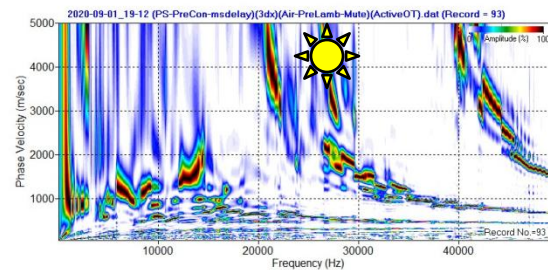
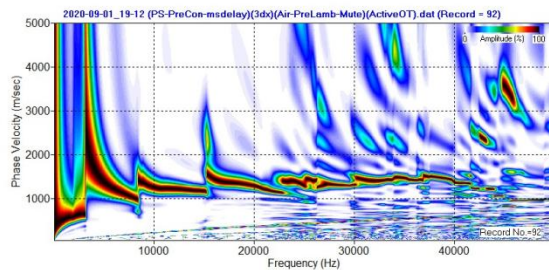
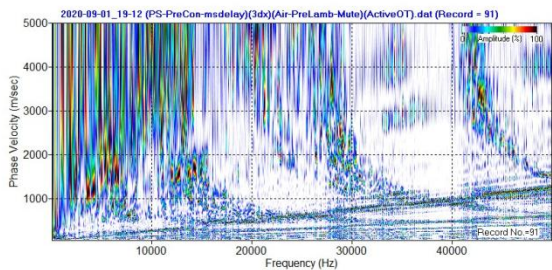

Dispersion Image

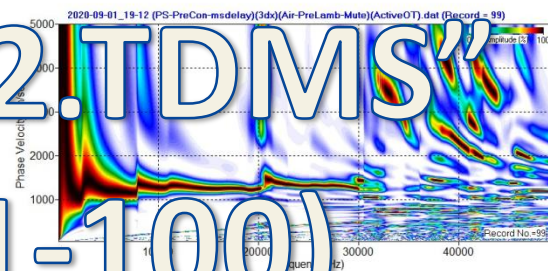
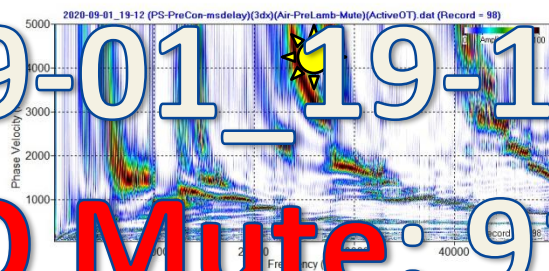
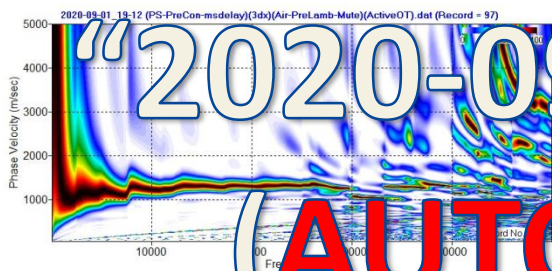

“2020-09-01_19-12.TDMS”

(AUTO Mute: 91-100)

(3dX-16-Channel)

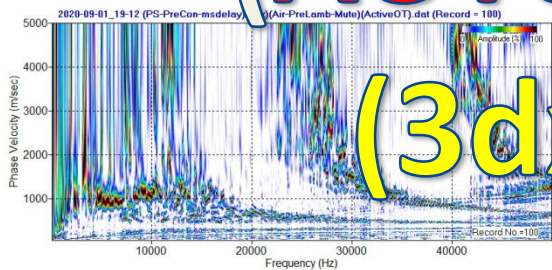

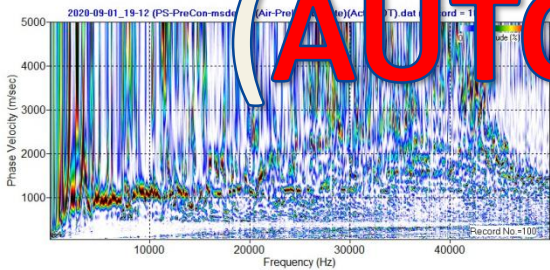
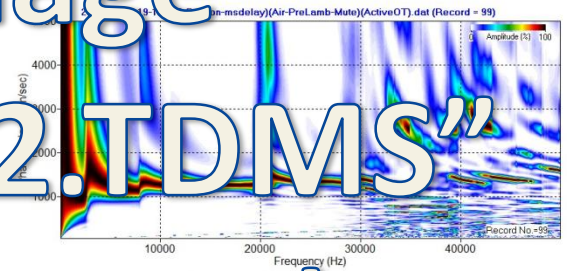
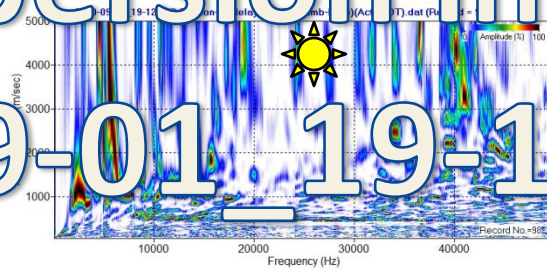
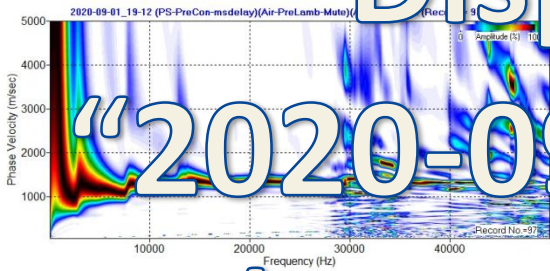
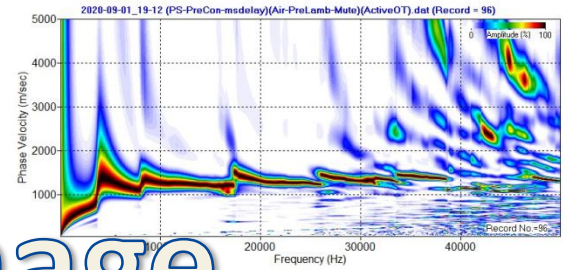
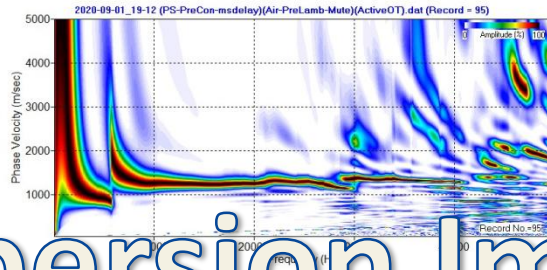
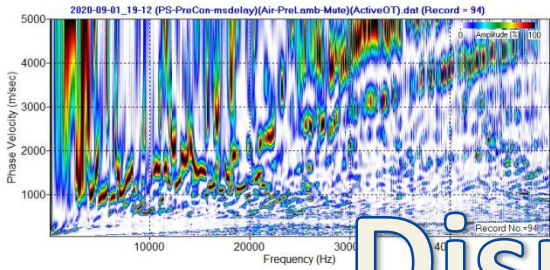
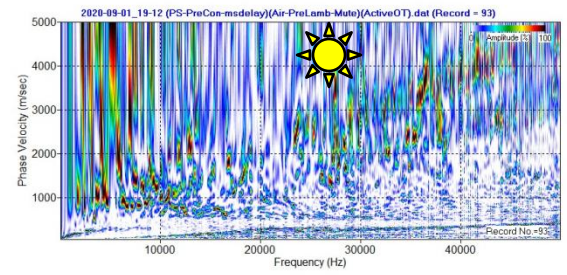
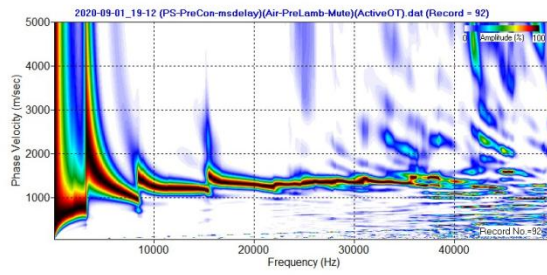
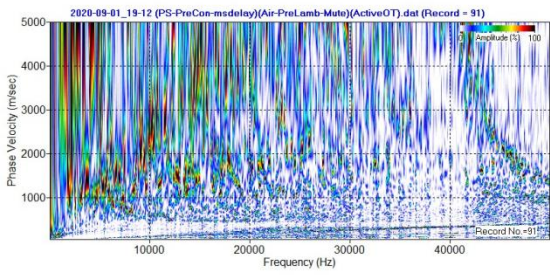

Dispersion Image

“2020-09-01_19-12.TDMS”

(AUTO Mute: 91-100)